

SUPPLY END

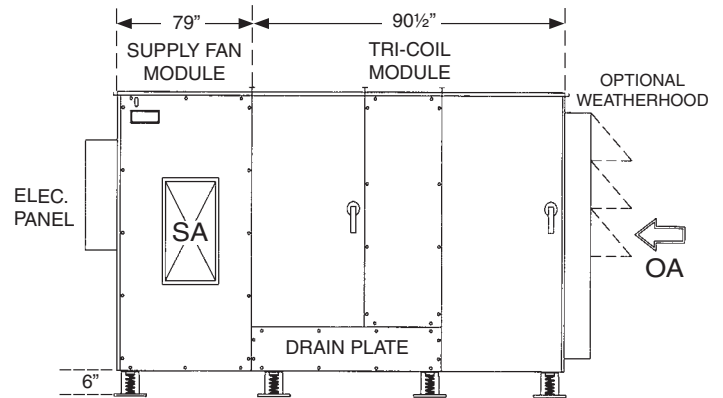

SUPPLY SIDE

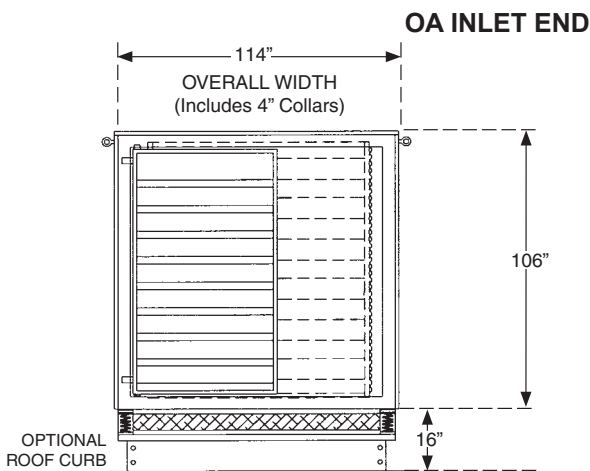

OA INLET END

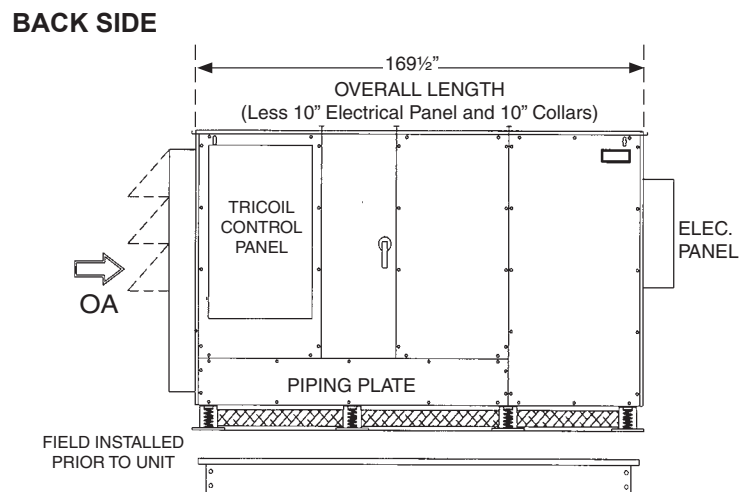

BACK SIDE

SUPPLY FAN PERFORMANCE AND MOTOR SELECTION GUIDE

(Intersect CFM with external static pressure to determine fan h.p.)

CFM	OUTLET VEL. FPM		0.5 ESP	1.0 ESP	1.5 ESP	2.0 ESP	2.5 ESP	3.0 ESP	3.5 ESP
18000	1933	RPM	697	738	778	816	854	892	N/A
		BHP	10.4	12.09	13.83	15.54	17.33	19.2	
		hp	15	15	20	20	20	25	
19000	2041	RPM	733	772	809	846	883	N/A	N/A
		BHP	12.11	13.89	15.66	17.5	19.41		
		hp	15	20	20	25	25		
20000	2148	RPM	760	797	833	868	903	N/A	N/A
		BHP	13.56	15.4	17.27	19.16	21.12		
		hp	20	20	20	25	25		
21000	2256	RPM	794	829	863	897	N/A	N/A	N/A
		BHP	15.48	17.39	19.31	21.32			
		hp	20	20	25	25			
22000	2363	RPM	823	857	890	923	N/A	N/A	N/A
		BHP	17.28	19.3	21.32	23.42			
		hp	20	25	25	30			

hp	208	240	480
15	41.0	38.0	19.0
20	54.0	50.0	24.9
25	66.0	60.0	30.0
30	78.0	71.0	35.0

	208	240	480
Damper Motor (ea.)	0.75	0.75	0.50
TRICOIL Pump Motor	NA	3.60	1.80
Hot Water Modulating Ball-Valve	0.20	0.20	0.10
Temperature Sensor (ea.)	0.50	0.50	0.25
Lights and Receptical	12.00	12.00	6.00
Variable Frequency Drive for Fan (ea.)	0.50	0.50	0.25
Variable Frequency Drive for TRICOIL	0.25	0.25	0.15

Performance numbers are based on optimum conditions. Consult factory for precise performance.