

PLAN VIEW

Right-Hand Unit

Left-Hand Unit Is Mirrored

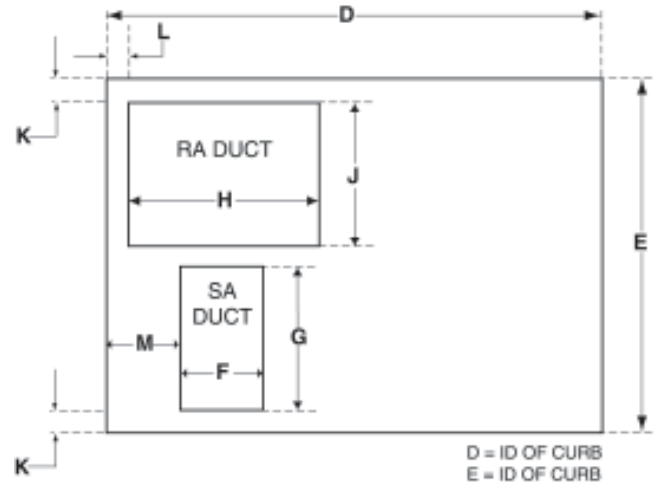
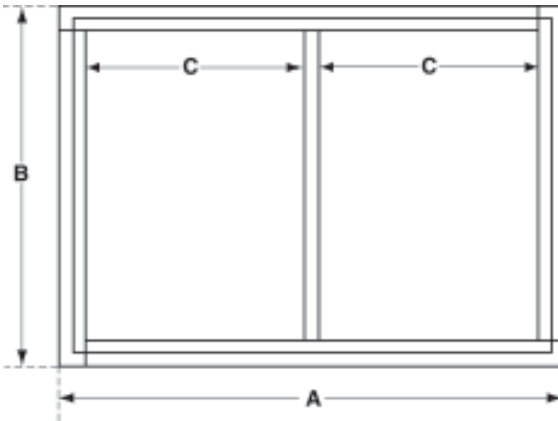

D = ID OF CURB
E = ID OF CURB

ROOF CURB DIMENSIONS												
MODEL	A	B	C	D	E	F=w	G=h	H=w	J=h	K	L	M
3820	161-1/2	46	75-1/4	153-1/2	38	10	16	17	15	1-1/4	1-1/2	9-1/16
4830	161-1/2	56	75-1/4	153-1/2	48	12	19	18	22	1-1/4	1-1/2	9-1/4
5840	173-1/2	66	81-1/4	165-1/2	58	13	21	24	27	1-1/4	1-1/2	9-7/16
5855	173-1/2	66	81-1/4	165-1/2	58	15	24	24	27	1-1/4	1-1/2	9-1/8
6875	189	76	89	181	68	18	29	32	29	1-1/4	1-1/2	11-3/16
6895	213	76	101	205	68	21	32	32	29	1-1/4	1-1/2	10-5/8
7812	213	86	101	205	78	23	35	36	36	1-1/4	1-1/2	10-13/16
8815	221-1/2	96	105-1/4	213-1/2	88	26	41	40	40	1-1/4	1-1/2	15-1/4
9617	235-1/2	106	112-1/4	227-1/2	98	29	44	40	47	1-1/4	1-1/2	15-11/16
9620	261-1/2	106	125-1/4	253-1/2	98	32	44	40	47	1-1/4	1-1/2	18-1/4

BERNER ENERGY RECOVERY CURBS:

Berner Energy uses heavy gauge aluminized steel construction for all roof curb bases. All curbs are built and pre-assembled in our factory, in order to greatly reduce the chances of any difficulty in field assembly, then shipped unassembled to job site. Minimal field assembly required. Curbs suggested match the above reference model series of desiccant based, all season energy recovery ventilator packages. These curbs were designed for modified drop-duct connections.

SPECIAL ORDER CURBS:

To request special order curbs to match pitched roofs, specify the exact height of each corner.

NOTE: NEVER SET A CURB ACROSS A VALLEY.

BERNER ENERGY ISO-RAILS:

Berner Energy heavy gauge, aluminized steel vibration isolation rails isolate the entire unit. They are weather-tight and field bolt-to-top of roof curb. Rails include pre-engineered, captive steel spring isolators, allowing deflection under load ranging from 1.0 to 1.3 inches. Basic models SFR and ERV have four (4) isolators. All other units have six (6) to ten (10) isolators. Iso-Rails are field leveled with built-in leveling bolts. Iso-Rail dimensions are the same as the size of the unit.

CONNECTIONS:

The first joint should be a short straight piece so you can connect to the factory flex connector collars from the inside.

VIBRATION ISO-RAIL

