

SUPPLY END

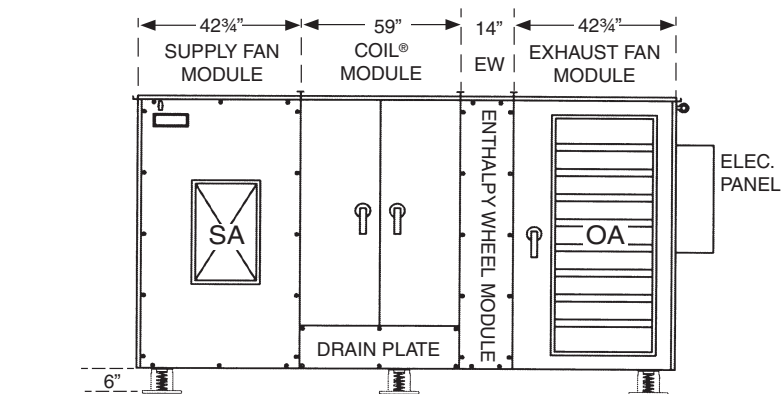

SUPPLY SIDE

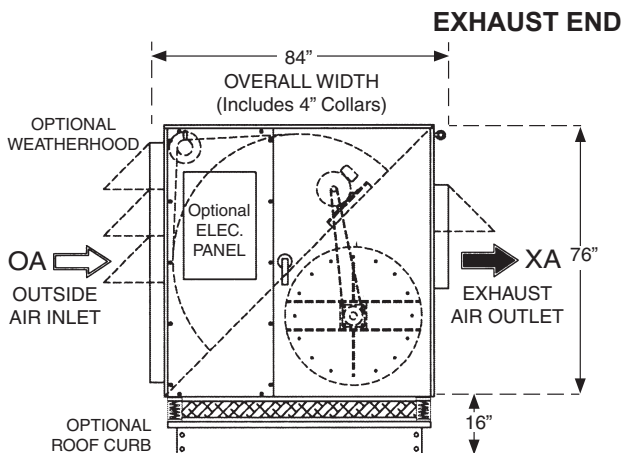

EXHAUST END

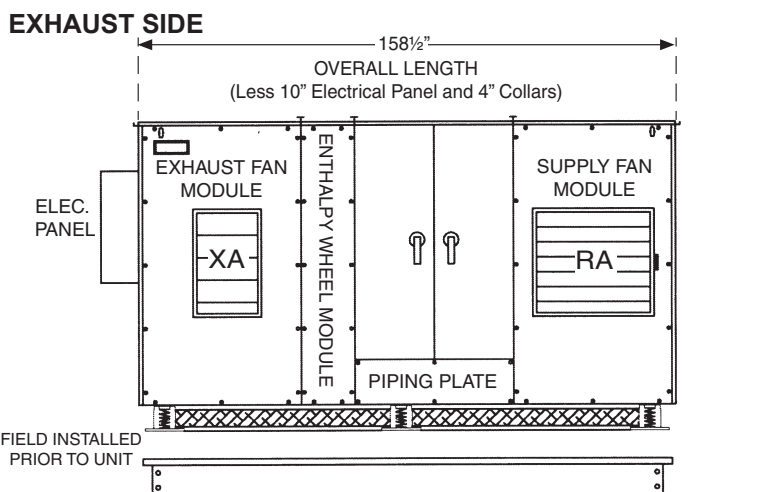

EXHAUST SIDE

## SUPPLY FAN PERFORMANCE AND MOTOR SELECTION GUIDE

(Intersect CFM with external static pressure to determine fan h.p.)

CFM	OUTLET VEL. FPM		0.5 ESP	1.0 ESP	1.5 ESP	2.0 ESP	2.5 ESP	3.0 ESP	3.5 ESP
7000	2029	RPM	1218	1290	1361	1429	1496	1561	N/A
		BHP	4.18	4.85	5.56	6.28	7.04	7.82	
		hp	5	7.5	7.5	7.5	10	10	
7250	2101	RPM	1247	1318	1387	1453	1519	N/A	N/A
		BHP	4.51	5.2	5.93	6.66	7.45		
		hp	7.5	7.5	7.5	10	10		
7500	2174	RPM	1284	1352	1491	1484	1548	N/A	N/A
		BHP	4.93	5.64	6.38	7.15	7.94		
		hp	7.5	7.5	7.5	10	10		
7750	2246	RPM	1315	1381	1446	1510	1572	N/A	N/A
		BHP	5.31	6.04	6.79	7.58	8.39		
		hp	7.5	7.5	10	10	10		
8000	2319	RPM	1359	1423	1486	1548	N/A	N/A	N/A
		BHP	5.86	6.61	7.39	8.2			
		hp	7.5	10	10	10			

## EXHAUST FAN PERFORMANCE AND MOTOR SELECTION GUIDE

(Intersect CFM with external static pressure to determine fan h.p.)

CFM	OUTLET VEL. FPM		0.5 ESP	1.0 ESP	1.5 ESP	2.0 ESP	2.5 ESP	3.0 ESP	3.5 ESP
7000	2029	RPM	1071	1148	1222	1295	1365	1433	1500
		BHP	2.96	3.58	4.22	4.9	5.6	6.33	7.09
		hp	5	5	5	7.5	7.5	7.5	10
7250	2101	RPM	1094	1169	1242	1312	1381	1448	1513
		BHP	3.16	3.79	4.46	5.14	5.86	6.61	7.37
		hp	5	5	5	7.5	7.5	10	10
7500	2174	RPM	1130	1203	1273	1342	1409	1474	1538
		BHP	3.48	4.14	4.82	5.53	6.27	7.03	7.82
		hp	5	5	5	7.5	7.5	10	10
7750	2246	RPM	1157	1227	1296	1363	1428	1492	1555
		BHP	3.74	4.41	5.11	5.84	6.58	7.36	8.17
		hp	5	7.5	5	7.5	10	10	10
8000	2319	RPM	1184	1253	1319	1385	1449	1511	1572
		BHP	4.01	4.71	5.41	6.16	6.93	7.71	8.52
		hp	5	7.5	7.5	7.5	10	10	10

hp	208	240	480
5	14.0	12.7	6.4
7.5	21.0	19.0	9.5
10	27.3	24.7	12.3

	208	240	480
1/3 hp	1.2	1.2	0.6

	208	240	480
Enthalpy Wheel Rotation Detection	0.20	0.20	0.10
Damper Motor (ea.)	0.75	0.75	0.50
Radiant Defrost Heater Pkg. (ea.)	4.57	3.95	1.97
Temperature Sensor (ea.)	0.50	0.50	0.25
Lights and Receptical	12.00	12.00	6.00
Variable Frequency Drive for Fan (ea.)	0.50	0.50	0.25

Performance numbers are based on optimum conditions. Consult factory for precise performance.