

SUPPLY END

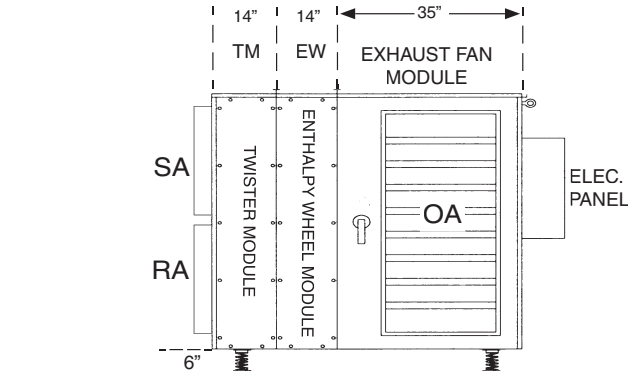

SUPPLY SIDE

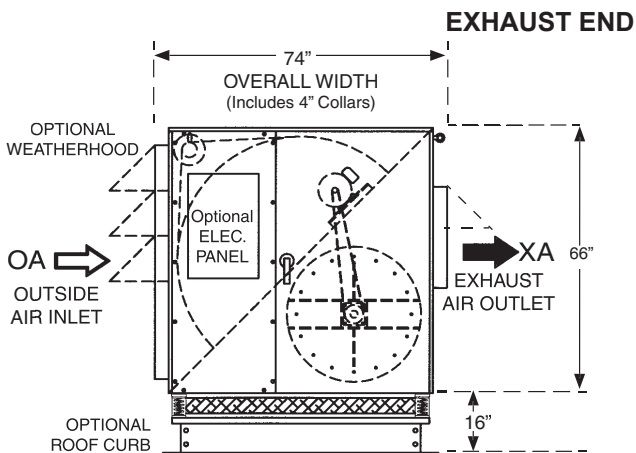

EXHAUST END

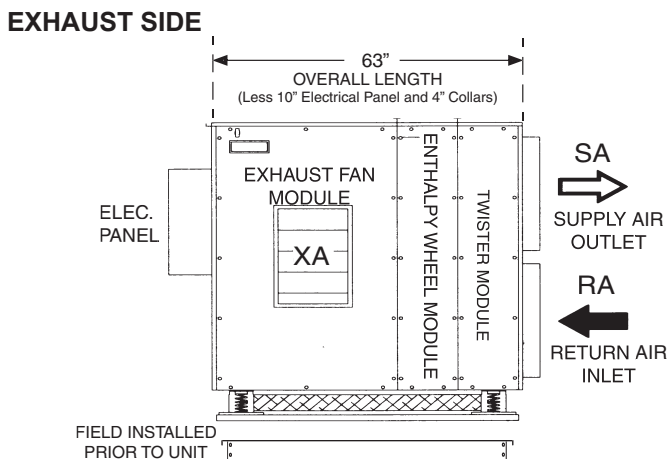

EXHAUST SIDE

SUPPLY FAN PERFORMANCE AND MOTOR SELECTION GUIDE

(Intersect CFM with external static pressure to determine fan h.p.)

CFM	OUTLET VEL. FPM		0.5 ESP	1.0 ESP	1.5 ESP	2.0 ESP	2.5 ESP	3.0 ESP	3.5 ESP
4750	2066	RPM	1264	1358	1450	1539	1626	1710	1793
		BHP	1.77	2.18	2.6	3.04	3.5	3.98	4.49
		hp	3	3	3	5	5	5	7.5
5000	2175	RPM	1307	1397	1486	1572	1655	1737	1817
		BHP	1.96	2.38	2.82	3.28	3.75	4.24	4.76
		hp	3	3	5	5	5	5	7.5
5500	2392	RPM	1411	1494	1575	1655	1733	1809	1884
		BHP	2.46	2.92	3.4	3.89	4.39	4.91	5.45
		hp	3	5	5	5	7.5	7.5	7.5
5750	2501	RPM	1458	1537	1616	1693	1768	1842	1914
		BHP	2.7	3.19	3.68	4.19	4.71	5.25	5.79
		hp	5	5	5	5	7.5	7.5	7.5
6000	2610	RPM	1506	1582	1657	1793	1804	1876	1946
		BHP	2.97	3.47	3.98	4.5	5.03	5.59	6.15
		hp	5	5	5	7.5	7.5	7.5	7.5

EXHAUST FAN PERFORMANCE AND MOTOR SELECTION GUIDE

(Intersect CFM with external static pressure to determine fan h.p.)

CFM	OUTLET VEL. FPM		0.5 ESP	1.0 ESP	1.5 ESP	2.0 ESP	2.5 ESP	3.0 ESP	3.5 ESP
4750	2066	RPM	1294	1388	1479	1567	1653	1737	1819
		BHP	1.9	2.31	2.74	3.19	3.65	4.14	4.65
		hp	3	3	5	5	5	5	7.5
5000	2175	RPM	1340	1492	1517	1602	1685	1766	1845
		BHP	2.11	2.54	2.99	3.45	3.93	4.43	4.94
		hp	3	3	5	5	5	7.5	7.5
5500	2392	RPM	1451	1533	1614	1693	1770	1845	1919
		BHP	2.68	3.15	3.63	4.13	4.64	5.17	5.71
		hp	5	5	5	5	7.5	7.5	7.5
5750	2501	RPM	1498	1577	1654	1730	1805	1878	N/A
		BHP	2.94	3.44	3.93	4.44	4.97	5.51	5.51
		hp	5	5	5	7.5	7.5	7.5	
6000	2610	RPM	1547	1622	1697	1771	1843	1914	N/A
		BHP	3.24	3.74	4.26	4.79	5.33	5.89	5.89
		hp	5	5	5	7.5	7.5	7.5	

FAN MOTOR AMP DRAW CHART

hp	208	240	480
3	8.6	8.4	4.2
5	14.0	12.7	6.4
7-1/2	21.0	19.0	9.5

WHEEL MOTOR AMP DRAW CHART

	208	240	480
1/4 hp	1.0	1.0	0.5

ACCESSORIES AMP DRAW CHART

	208	240	480
Enthalpy Wheel Rotation Detection	0.20	0.20	0.10
Damper Motor (ea.)	0.75	0.75	0.50
Radiant Defrost Heater Pkg. (ea.)	4.57	3.95	1.97
Temperature Sensor (ea.)	0.50	0.50	0.25
Lights and Receptical	12.00	12.00	6.00
Variable Frequency Drive for Fan (ea.)	0.50	0.50	0.25

Performance numbers are based on optimum conditions. Consult factory for precise performance.