

SUPPLY END

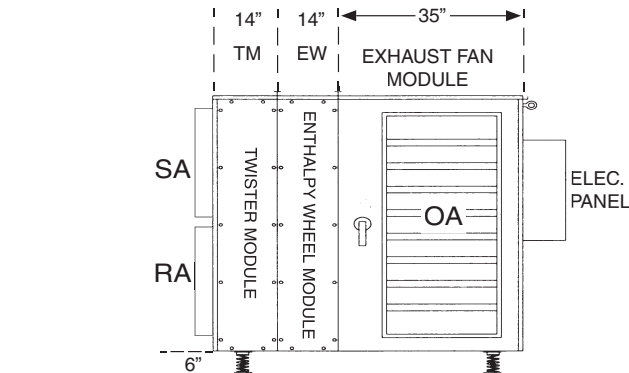

SUPPLY SIDE

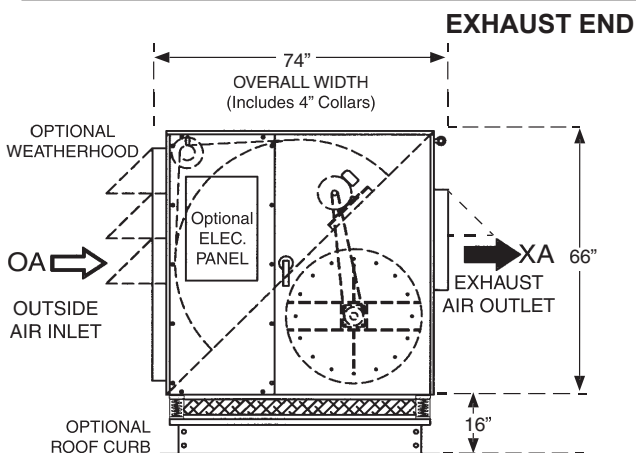

EXHAUST END

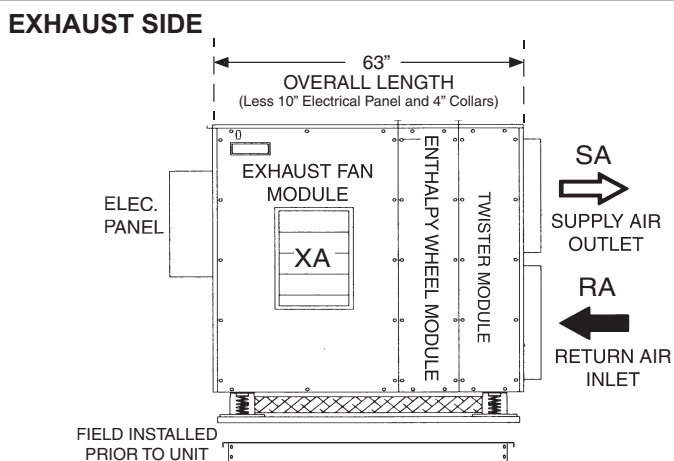

EXHAUST SIDE

SUPPLY FAN PERFORMANCE AND MOTOR SELECTION GUIDE

(Intersect CFM with external static pressure to determine fan h.p.)

CFM	OUTLET VEL. FPM		0.5 ESP	1.0 ESP	1.5 ESP	2.0 ESP	2.5 ESP	3.0 ESP	3.5 ESP
3500	1824	RPM	1246	1362	1473	1581	1685	1786	1883
		BHP	1.07	1.38	1.7	2.04	2.39	2.77	3.15
		hp	1.5	2	2	3	3	5	5
3750	1954	RPM	1304	1413	1519	1622	1721	1818	1911
		BHP	1.23	1.55	1.89	2.24	2.61	3	3.39
		hp	1.5	2	3	3	3	5	5
4000	2084	RPM	1363	1467	1567	1665	1760	1853	1943
		BHP	1.4	1.75	2.09	2.46	2.84	3.24	3.65
		hp	2	3	3	3	5	5	5
4250	2215	RPM	1428	1526	1621	1715	1806	1895	1981
		BHP	1.61	1.97	2.33	2.72	3.12	3.53	3.95
		hp	2	3	3	5	5	5	5
4500	2345	RPM	1495	1588	1679	1768	1855	1940	2024
		BHP	1.84	2.22	2.61	3	3.42	3.84	4.28
		hp	3	3	3	5	5	5	5

EXHAUST FAN PERFORMANCE AND MOTOR SELECTION GUIDE

(Intersect CFM with external static pressure to determine fan h.p.)

CFM	OUTLET VEL. FPM		0.5 ESP	1.0 ESP	1.5 ESP	2.0 ESP	2.5 ESP	3.0 ESP	3.5 ESP
3500	1824	RPM	1281	1396	1506	1613	1716	1815	1912
		BHP	1.16	1.47	1.8	2.14	2.5	2.88	3.28
		hp	1.5	2	3	3	3	5	5
3750	1954	RPM	1343	1452	1556	1658	1756	1852	1945
		BHP	1.34	1.67	2.01	2.37	2.74	3.14	3.54
		hp	2	2	3	3	5	5	5
4000	2084	RPM	1405	1507	1607	1704	1790	1889	1979
		BHP	1.54	1.88	2.24	2.61	2.97	3.4	3.82
		hp	2	3	3	3	5	5	5
4250	2215	RPM	1473	1570	1665	1757	1847	1935	2020
		BHP	1.77	2.14	2.51	2.91	3.3	3.72	4.15
		hp	3	3	3	5	5	5	5
4500	2345	RPM	1544	1635	1725	1814	1900	1984	2066
		BHP	2.04	2.42	2.81	3.22	3.64	4.07	4.51
		hp	3	3	5	5	5	5	7.5

FAN MOTOR AMP DRAW CHART

hp	208	240	480
1-1/2	4.5	4.4	2.2
2	6.0	5.9	3.0
3	8.6	8.4	4.2
5	14.0	12.7	6.4
7-1/2	21.0	19.0	9.5

WHEEL MOTOR AMP DRAW CHART

	208	240	480
1/4 hp	1.0	1.0	0.5

ACCESSORIES AMP DRAW CHART

	208	240	480
Enthalpy Wheel Rotation Detection	0.20	0.20	0.10
Damper Motor (ea.)	0.75	0.75	0.50
Radiant Defrost Heater Pkg. (ea.)	4.57	3.95	1.97
Temperature Sensor (ea.)	0.50	0.50	0.25
Lights and Receptical	12.00	12.00	6.00
Variable Frequency Drive for Fan (ea.)	0.50	0.50	0.25

Performance numbers are based on optimum conditions. Consult factory for precise performance.