

PLAN VIEW

Right-Hand Unit

Left-Hand Unit Is Mirrored

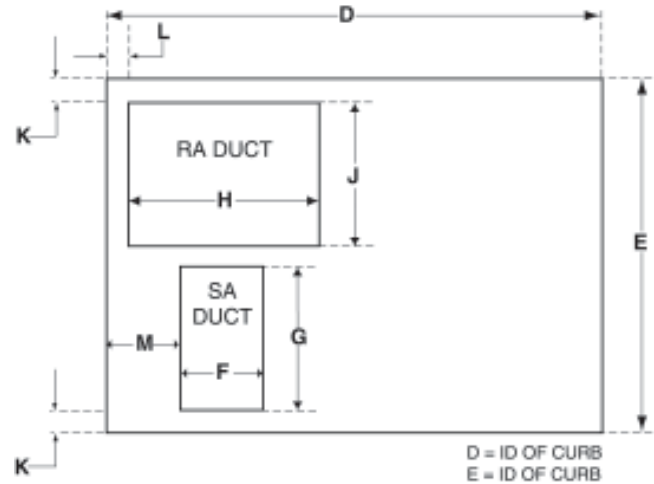
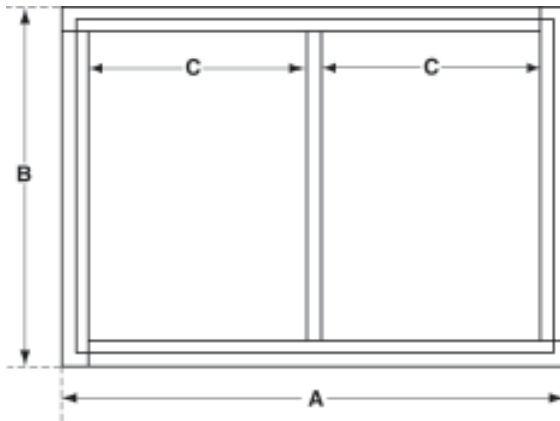

D = ID OF CURB
E = ID OF CURB

ROOF CURB DIMENSIONS												
MODEL	A	B	C	D	E	F=w	G=h	H=w	J=h	K	L	M
3820	72	46	NA	64	38	10	16	17	15	1-1/4	1-1/2	9-1/16
4830	72	56	NA	64	48	12	19	18	22	1-1/4	1-1/2	9-1/4
5840	84	66	NA	76	58	13	21	24	27	1-1/4	1-1/2	9-7/16
5855	84	66	NA	76	58	15	24	24	27	1-1/4	1-1/2	9-1/8
6875	99-1/2	76	44-1/4	91-1/2	68	18	29	32	29	1-1/4	1-1/2	11-3/16
6895	123-1/2	76	56-1/4	115-1/2	68	21	32	32	29	1-1/4	1-1/2	10-5/8
7812	123-1/2	86	56-1/4	115-1/2	78	23	35	36	36	1-1/4	1-1/2	10-13/16
8815	132	96	60-1/2	124	88	26	41	40	40	1-1/4	1-1/2	15-1/4
9617	146	106	67-1/2	138	98	29	44	40	47	1-1/4	1-1/2	15-11/16
9620	172	106	80-1/2	164	98	32	44	40	47	1-1/4	1-1/2	18-1/4

BERNER ENERGY RECOVERY CURBS:

Berner Energy uses heavy gauge aluminized steel construction for all roof curb bases. All curbs are built and pre-assembled in our factory, in order to greatly reduce the chances of any difficulty in field assembly, then shipped unassembled to job site. Minimal field assembly required. Curbs suggested match the above reference model series of desiccant based, all season energy recovery ventilator packages. These curbs were designed for modified drop-duct connections.

SPECIAL ORDER CURBS:

To request special order curbs to match pitched roofs, specify the exact height of each corner.

NOTE: NEVER SET A CURB ACROSS A VALLEY.

BERNER ENERGY ISO-RAILS:

Berner Energy heavy gauge, aluminized steel vibration isolation rails isolate the entire unit. They are weather-tight and field bolt-to-top of roof curb. Rails include pre-engineered, captive steel spring isolators, allowing deflection under load ranging from 1.0 to 1.3 inches. Basic models SFR and ERV have four (4) isolators. All other units have six (6) to ten (10) isolators. Iso-Rails are field leveled with built-in leveling bolts. Iso-Rail dimensions are the same as the size of the unit.

CONNECTIONS:

The first joint should be a short straight piece so you can connect to the factory flex connector collars from the inside.

