

SUPPLY END

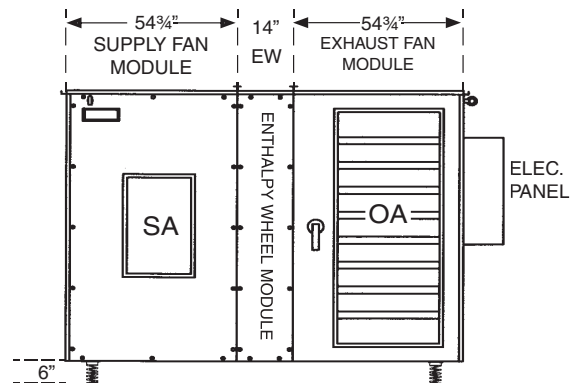

SUPPLY SIDE

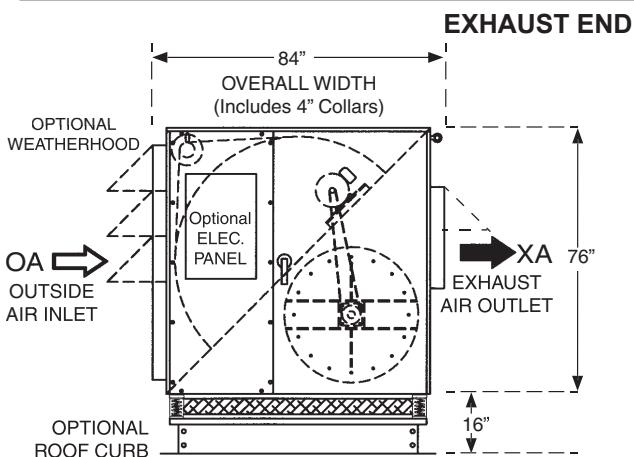

EXHAUST END

EXHAUST SIDE

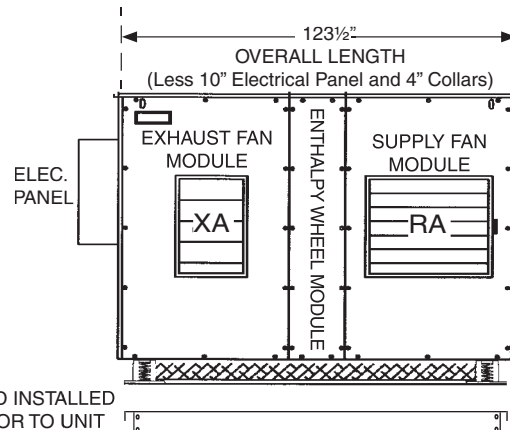

SUPPLY FAN PERFORMANCE AND MOTOR SELECTION GUIDE

(Intersect CFM with external static pressure to determine fan h.p.)

CGM	OUTLET VEL. FPM		0.5 ESP	1.0 ESP	1.5 ESP	2.0 ESP	2.5 ESP	3.0 ESP	3.5 ESP
9000	2148	RPM	1042	1101	1158	1213	1266	1318	1368
		BHP	4.48	5.24	6.03	6.83	7.65	8.52	9.4
		hp	7.5	7.5	7.5	10	10	10	15
9250	2208	RPM	1062	1120	1176	1230	1283	1334	1383
		BHP	4.74	5.53	6.33	7.15	8.01	8.88	9.77
		hp	7.5	7.5	7.5	10	10	15	15
9500	2267	RPM	1083	1140	1195	1248	1299	1349	N/A
		BHP	5.03	5.84	6.66	7.5	8.35	9.23	
		hp	7.5	7.5	10	10	10	15	
9750	2327	RPM	1103	1159	1213	1265	1319	1365	N/A
		BHP	5.32	6.14	6.98	7.84	8.77	9.61	
		hp	7.5	7.5	10	10	15	15	
10000	2387	RPM	1123	1178	1231	1282	1332	1380	N/A
		BHP	5.62	6.46	7.32	8.18	9.08	9.98	
		hp	7.5	7.5	10	10	15	15	

EXHAUST FAN PERFORMANCE AND MOTOR SELECTION GUIDE

(Intersect CFM with external static pressure to determine fan h.p.)

CGM	OUTLET VEL. FPM		0.5 ESP	1.0 ESP	1.5 ESP	2.0 ESP	2.5 ESP	3.0 ESP	3.5 ESP
9000	2148	RPM	1025	1085	1142	1198	1251	1304	1354
		BHP	4.27	5.03	5.8	6.61	7.42	8.28	9.15
		hp	5	7.5	7.5	10	10	10	15
9250	2208	RPM	1044	1103	1160	1214	1267	1319	1369
		BHP	4.51	5.29	6.1	6.9	7.74	8.62	9.51
		hp	7.5	7.5	7.5	10	10	10	15
9500	2267	RPM	1065	1123	1179	1232	1284	1334	1384
		BHP	4.79	5.59	6.42	7.24	8.09	8.96	9.88
		hp	7.5	7.5	7.5	10	10	15	15
9750	2327	RPM	1085	1142	1196	1249	1300	1349	N/A
		BHP	5.07	5.89	6.71	7.57	8.44	9.31	
		hp	7.5	7.5	10	10	10	15	
10000	2387	RPM	1104	1159	1213	1265	1315	1364	N/A
		BHP	5.34	6.16	7.02	7.89	8.77	9.67	
		hp	7.5	7.5	10	10	15	15	

hp	208	240	480
5	14.0	12.7	6.4
7-1/2	21.0	19.0	9.5
10	27.3	24.7	12.3
15	41.0	38.0	19.0

	208	240	480
1/3 hp	1.2	1.2	0.6

	208	240	480
Enthalpy Wheel Rotation Detection	0.20	0.20	0.10
Damper Motor (ea.)	0.75	0.75	0.50
Radiant Defrost Heater Pkg. (ea.)	4.57	3.95	1.97
Temperature Sensor (ea.)	0.50	0.50	0.25
Lights and Receptical	12.00	12.00	6.00
Variable Frequency Drive for Fan (ea.)	0.50	0.50	0.25

Performance numbers are based on optimum conditions. Consult factory for precise performance.