

SUPPLY END

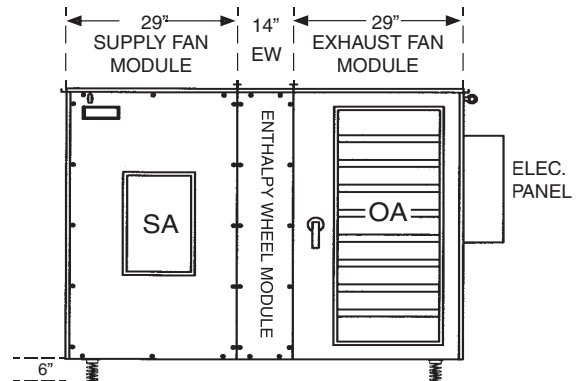

SUPPLY SIDE

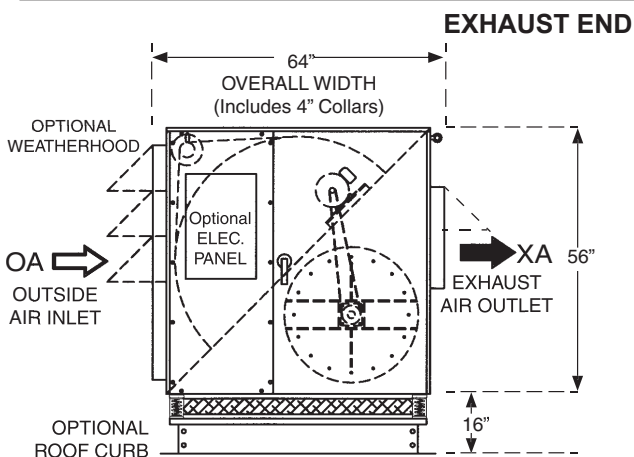

EXHAUST END

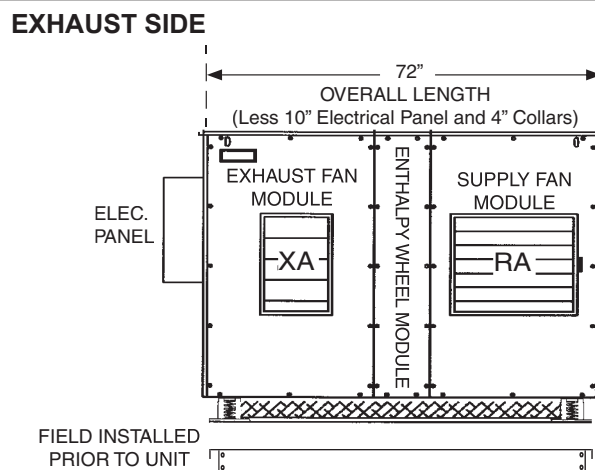

EXHAUST SIDE

4830-ERV

2,500 to 3,500 CFM

March, 2003

SUPPLY FAN PERFORMANCE AND MOTOR SELECTION GUIDE

(Intersect CFM with external static pressure to determine fan h.p.)

CFM	OUTLET VEL. FPM		0.5 ESP	1.0 ESP	1.5 ESP	2.0 ESP	2.5 ESP	3.0 ESP	3.5 ESP
2500	1592	RPM	1412	1537	1653	1762	1868	1971	2071
		BHP	0.94	1.2	1.47	1.75	2.05	2.37	2.7
		hp	1.5	1.5	2	3	3	3	5
2750	1752	RPM	1492	1611	1721	1826	1925	2022	2117
		BHP	1.12	1.39	1.67	1.98	2.29	2.62	2.96
		hp	1.5	2	2	3	3	5	5
3000	1911	RPM	1583	1696	1801	1901	1996	2087	2176
		BHP	1.34	1.63	1.93	2.25	2.58	2.92	3.28
		hp	2	2	3	3	3	5	5
3250	2070	RPM	1681	1788	1888	1983	2075	2162	2247
		BHP	1.6	1.92	2.24	2.57	2.92	3.28	3.65
		hp	2	3	3	3	5	5	5
3500	2229	RPM	1769	1871	1967	2058	2146	2231	2312
		BHP	1.87	2.21	2.55	2.9	3.26	3.63	4.02
		hp	3	3	3	5	5	5	5

EXHAUST FAN PERFORMANCE AND MOTOR SELECTION GUIDE

(Intersect CFM with external static pressure to determine fan h.p.)

CFM	OUTLET VEL. FPM		0.5 ESP	1.0 ESP	1.5 ESP	2.0 ESP	2.5 ESP	3.0 ESP	3.5 ESP
2500	1592	RPM	1372	1500	1619	1730	1837	1940	2024
		BHP	0.87	1.12	1.38	1.67	1.96	2.27	2.61
		hp	1.5	1.5	2	2	3	3	5
2750	1752	RPM	1454	1576	1689	1795	1896	1993	2088
		BHP	1.04	1.31	1.59	1.88	2.19	2.52	2.86
		hp	1.5	2	2	3	3	3	5
3000	1911	RPM	1548	1663	1770	1871	1968	2060	2150
		BHP	1.25	1.54	1.84	2.15	2.48	2.82	3.17
		hp	1.5	2	3	3	3	5	5
3250	2070	RPM	1650	1759	1861	1957	2049	2138	2223
		BHP	1.52	1.83	2.15	2.48	2.82	3.18	3.54
		hp	2	3	3	3	5	5	5
3500	2229	RPM	1739	1843	1941	2033	2122	2207	2290
		BHP	1.78	2.11	2.45	2.8	3.16	3.53	3.91
		hp	3	3	3	5	5	5	5

FAN MOTOR AMP DRAW CHART

hp	208	240	480
1-1/2	4.5	4.4	2.2
2	6.0	5.9	3.0
3	8.6	8.4	4.2
5	14.0	12.7	6.4

WHEEL MOTOR AMP DRAW CHART

	208	240	480
1/4 hp	1.0	1.0	0.5

ACCESSORIES AMP DRAW CHART

	208	240	480
Enthalpy Wheel Rotation Detection	0.20	0.20	0.10
Damper Motor (ea.)	0.75	0.75	0.50
Radiant Defrost Heater Pkg. (ea.)	4.57	3.95	1.97
Temperature Sensor (ea.)	0.50	0.50	0.25
Lights and Receptical	12.00	12.00	6.00
Variable Frequency Drive for Fan (ea.)	0.50	0.50	0.25

Performance numbers are based on optimum conditions. Consult factory for precise performance.

Berner Energy Recovery Incorporated

111 Progress Avenue, New Castle, PA 16101 / Telephone (724) 657-5301 / FAX (724) 652-0682 / www.bernerenergy.com / info@bernerenergy.com

©Copyright, 2002 Berner Energy Recovery, Inc.