

**SUPPLY END**

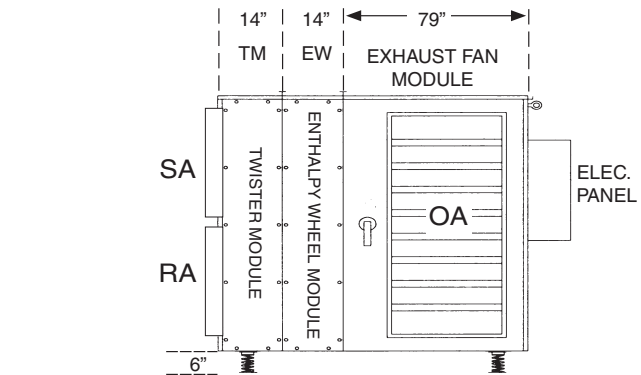

**SUPPLY SIDE**

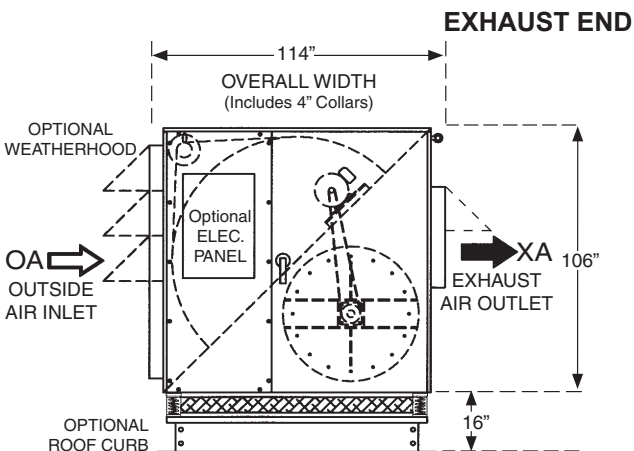

**EXHAUST END**

**EXHAUST SIDE**

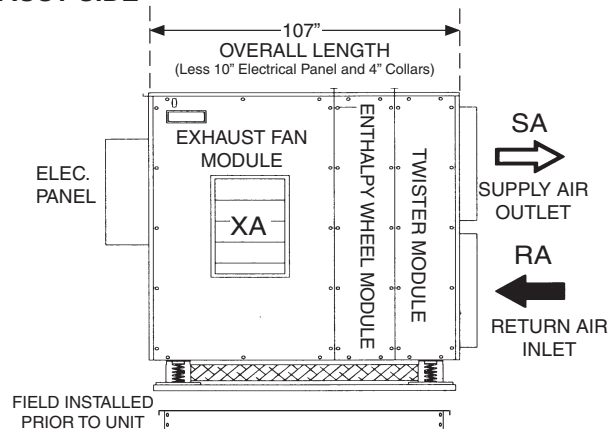

## SUPPLY FAN PERFORMANCE AND MOTOR SELECTION GUIDE

(Intersect CFM with external static pressure to determine fan h.p.)

CFM	OUTLET VEL. FPM		0.5 ESP	1.0 ESP	1.5 ESP	2.0 ESP	2.5 ESP	3.0 ESP	3.5 ESP
18000	1933	RPM	603	645	687	727	767	806	844
		BHP	6.89	8.39	10	11.63	13.34	15.09	16.85
		hp	10	10	15	15	20	20	20
19000	2041	RPM	624	665	704	743	781	819	856
		BHP	7.63	9.23	10.84	12.56	14.31	16.15	18.01
		hp	10	15	15	15	20	20	25
20000	2148	RPM	649	688	726	763	800	836	871
		BHP	8.57	10.23	11.94	13.7	15.56	17.44	19.33
		hp	10	15	15	20	20	25	25
21000	2256	RPM	643	710	747	782	818	852	886
		BHP	9.54	11.25	13.05	14.84	16.78	18.68	20.66
		hp	15	15	15	20	20	25	25
22000	2363	RPM	698	734	769	803	837	870	903
		BHP	10.62	12.43	14.27	16.14	18.1	20.08	22.14
		hp	15	15	20	20	25	25	30

## EXHAUST FAN PERFORMANCE AND MOTOR SELECTION GUIDE

(Intersect CFM with external static pressure to determine fan h.p.)

CFM	OUTLET VEL. FPM		0.5 ESP	1.0 ESP	1.5 ESP	2.0 ESP	2.5 ESP	3.0 ESP	3.5 ESP
18000	1933	RPM	616	658	699	739	779	818	856
		BHP	7.35	8.88	10.48	12.13	13.87	15.64	17.43
		hp	10	15	15	15	20	20	25
19000	2041	RPM	638	678	718	756	794	832	868
		BHP	8.17	9.75	11.45	13.15	14.93	16.8	18.63
		hp	10	15	15	20	20	20	25
20000	2148	RPM	664	702	740	877	813	849	884
		BHP	9.2	10.85	12.6	14.39	16.22	18.13	20.05
		hp	15	15	15	20	20	25	25
21000	2256	RPM	689	726	762	797	832	867	901
		BHP	10.27	12.02	13.81	15.64	17.55	19.55	21.56
		hp	15	15	20	20	25	25	25
22000	2363	RPM	715	751	785	819	853	886	N/A
		BHP	11.47	13.32	15.14	17.05	19.05	21.07	
		hp	15	20	20	20	25	25	

### FAN MOTOR AMP DRAW CHART

hp	208	240	480
10	27.3	24.7	12.3
15	41.0	38.0	19.0
20	54.0	50.0	24.9
25	66.0	60.0	30.0
30	78.0	71.0	35.0

### WHEEL MOTOR AMP DRAW CHART

	208	240	480
1/2 hp	1.8	1.8	0.9

### ACCESSORIES AMP DRAW CHART

	208	240	480
Enthalpy Wheel Rotation Detection	0.20	0.20	0.10
Damper Motor (ea.)	0.75	0.75	0.50
Radiant Defrost Heater Pkg. (ea.)	4.57	3.95	1.97
Temperature Sensor (ea.)	0.50	0.50	0.25
Lights and Receptical	12.00	12.00	6.00
Variable Frequency Drive for Fan (ea.)	0.50	0.50	0.25

Performance numbers are based on optimum conditions. Consult factory for precise performance.