

SUPPLY END

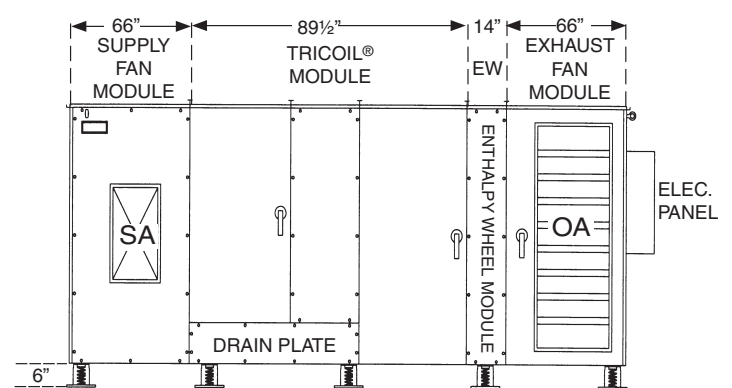

SUPPLY SIDE

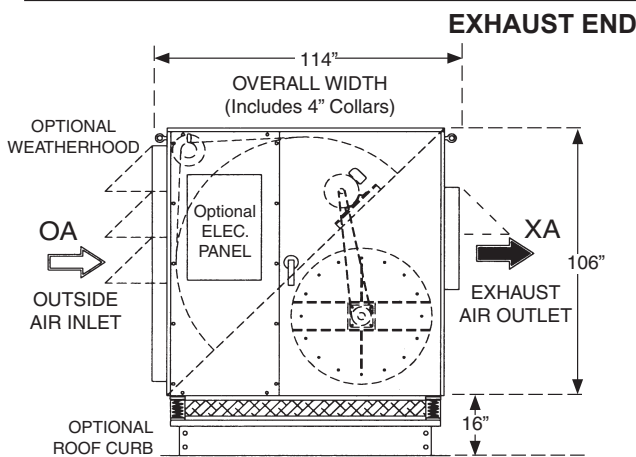

EXHAUST END

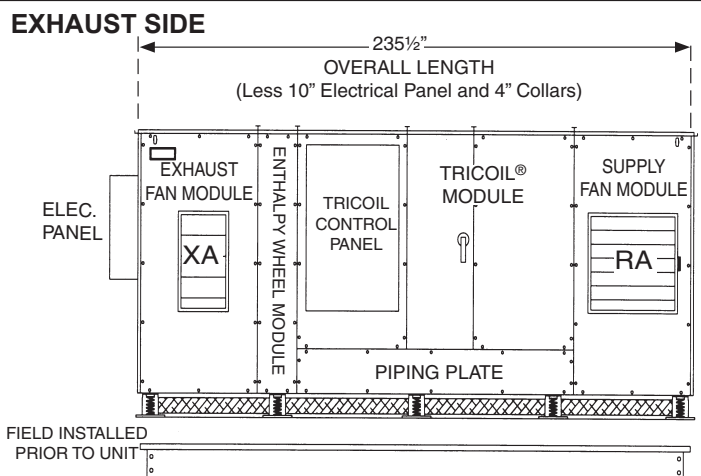

EXHAUST SIDE

## SUPPLY FAN PERFORMANCE AND MOTOR SELECTION GUIDE

(Intersect CFM with external static pressure to determine fan h.p.)

CFM	OUTLET VEL. FPM		0.5 ESP	1.0 ESP	1.5 ESP	2.0 ESP	2.5 ESP	3.0 ESP	3.5 ESP
16000	2089	RPM	869	910	950	989	N/A	N/A	N/A
		BHP	12.17	13.7	15.25	16.81			
		hp	15	20	20	15			
16500	2154	RPM	875	915	957	993	N/A	N/A	N/A
		BHP	12.53	14.08	15.78	17.28			
		hp	15	20	20	15			
17000	2220	RPM	924	945	983	N/A	N/A	N/A	N/A
		BHP	14.62	15.5	17.13				
		hp	20	20	20				
17500	2285	RPM	933	971	N/A	N/A	N/A	N/A	N/A
		BHP	15.16	16.83					
		hp	20	20					
18000	2350	RPM	954	991	N/A	N/A	N/A	N/A	N/A
		BHP	16.24	17.95					
		hp	20	25					

## EXHAUST FAN PERFORMANCE AND MOTOR SELECTION GUIDE

(Intersect CFM with external static pressure to determine fan h.p.)

CFM	OUTLET VEL. FPM		0.5 ESP	1.0 ESP	1.5 ESP	2.0 ESP	2.5 ESP	3.0 ESP	3.5 ESP
16000	2089	RPM	707	750	793	835	876	917	957
		BHP	6.81	8.12	9.51	10.95	12.42	13.96	15.53
		hp	10	10	15	15	15	20	20
16500	2154	RPM	709	752	794	835	875	915	954
		BHP	6.84	8.2	9.6	11.05	12.53	14.08	15.65
		hp	10	10	15	15	15	20	20
17000	2220	RPM	738	779	820	860	899	937	976
		BHP	7.73	9.11	10.57	12.07	13.6	15.16	16.83
		hp	10	15	15	15	20	20	20
17500	2285	RPM	757	797	836	875	914	951	988
		BHP	8.34	9.76	11.22	12.75	14.36	15.94	17.58
		hp	10	15	15	15	20	20	25
18000	2350	RPM	776	815	854	892	929	966	N/A
		BHP	8.98	10.44	11.97	13.53	15.13	16.79	
		hp	15	15	15	20	20	20	

hp	208	240	480
10	27.3	24.7	12.3
15	41.0	38.0	19.0
20	54.0	50.0	24.9

	208	240	480
1/2 hp	1.8	1.8	0.9

Performance numbers are based on optimum conditions. Consult factory for precise performance.

	208	240	480
Enthalpy Wheel Rotation Detection	0.20	0.20	0.10
Damper Motor (ea.)	0.75	0.75	0.50
Radiant Defrost Heater Pkg. (ea.)	4.57	3.95	1.97
TRICOIL Pump Motor	4.00	4.00	2.00
Hot Water Modulating Ball-Valve	0.20	0.20	0.10
Temperature Sensor (ea.)	0.50	0.50	0.25
Lights and Receptical	12.00	12.00	6.00
Variable Frequency Drive for Fan (ea.)	0.50	0.50	0.25
Variable Frequency Drive for TRICOIL	0.25	0.25	0.15