

SUPPLY END

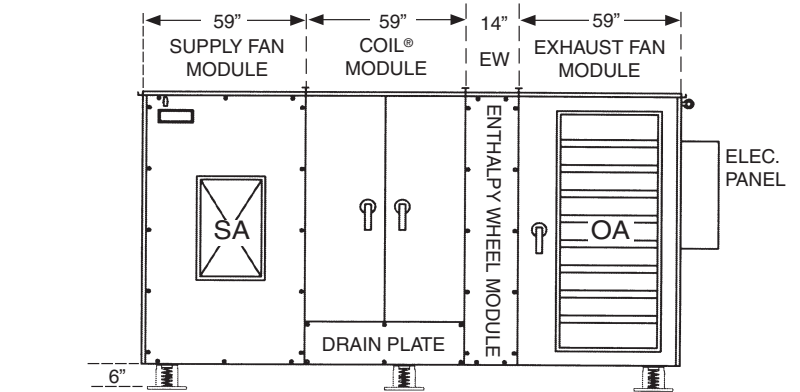

SUPPLY SIDE

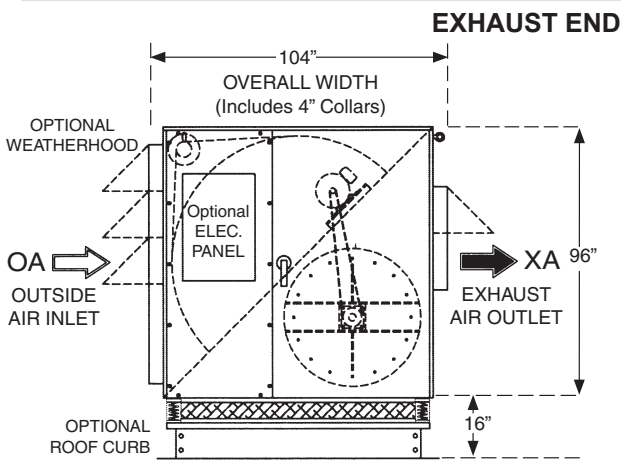

EXHAUST END

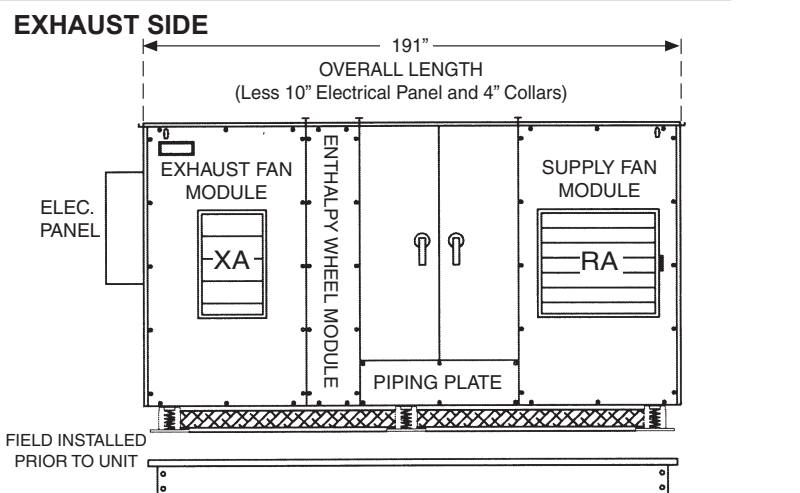

EXHAUST SIDE

SUPPLY FAN PERFORMANCE AND MOTOR SELECTION GUIDE

(Intersect CFM with external static pressure to determine fan h.p.)

CFM	OUTLET VEL. FPM		0.5 ESP	1.0 ESP	1.5 ESP	2.0 ESP	2.5 ESP	3.0 ESP	3.5 ESP
14000	2236	RPM	936	981	1025	1067	1108	N/A	N/A
		BHP	8.78	10.01	11.27	12.55	13.87		
		hp	15	15	15	15	20		
14500	2316	RPM	974	1017	1059	1100	1140	N/A	N/A
		BHP	9.89	11.15	12.44	13.77	15.14		
		hp	15	15	15	20	20		
15000	2396	RPM	1001	1043	1084	1124	N/A	N/A	N/A
		BHP	10.75	12.05	13.38	14.75			
		hp	15	15	20	20			
15500	2476	RPM	1027	1068	1108	N/A	N/A	N/A	N/A
		BHP	11.62	12.97	14.34				
		hp	15	15	20				
16000	2556	RPM	1053	1093	1132	N/A	N/A	N/A	NA
		BHP	12.54	13.93	15.34				
		hp	15	20	20				

EXHAUST FAN PERFORMANCE AND MOTOR SELECTION GUIDE

(Intersect CFM with external static pressure to determine fan h.p.)

CFM	OUTLET VEL. FPM		0.5 ESP	1.0 ESP	1.5 ESP	2.0 ESP	2.5 ESP	3.0 ESP	3.5 ESP
14000	2236	RPM	848	896	943	988	1031	1073	1114
		BHP	6.6	7.76	8.97	10.21	11.45	12.74	14.07
		hp	10	10	15	15	15	15	20
14500	2316	RPM	875	922	967	1010	1053	1093	1134
		BHP	7.25	8.46	9.69	10.94	12.25	13.53	14.93
		hp	10	10	15	15	15	20	20
15000	2396	RPM	901	946	990	1033	1074	1114	N/A
		BHP	7.91	9.14	10.42	11.74	13.05	14.4	
		hp	10	15	15	15	20	20	
15500	2476	PM	922	966	1009	1051	1091	1130	N/A
		BHP	8.47	9.74	11.05	12.4	13.75	15.72	
		hp	10	15	15	15	20	20	
16000	2556	RPM	945	988	1030	1071	1110	N/A	NA
		BHP	9.12	10.43	11.78	13.16	14.54		
		hp	15	15	15	20	20		

FAN MOTOR AMP DRAW CHART

hp	208	240	480
10	27.3	24.7	12.3
15	41.0	38.0	19.0
20	54.0	50.0	24.9

WHEEL MOTOR AMP DRAW CHART

	208	240	480
1/2 hp	1.8	1.8	0.9

ACCESSORIES AMP DRAW CHART

	208	240	480
Enthalpy Wheel Rotation Detection	0.20	0.20	0.10
Damper Motor (ea.)	0.75	0.75	0.50
Radiant Defrost Heater Pkg. (ea.)	4.57	3.95	1.97
Temperature Sensor (ea.)	0.50	0.50	0.25
Lights and Receptical	12.00	12.00	6.00
Variable Frequency Drive for Fan (ea.)	0.50	0.50	0.25

Performance numbers are based on optimum conditions. Consult factory for precise performance.