

SUPPLY END

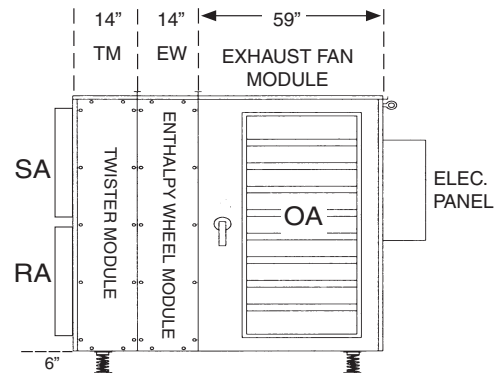

SUPPLY SIDE

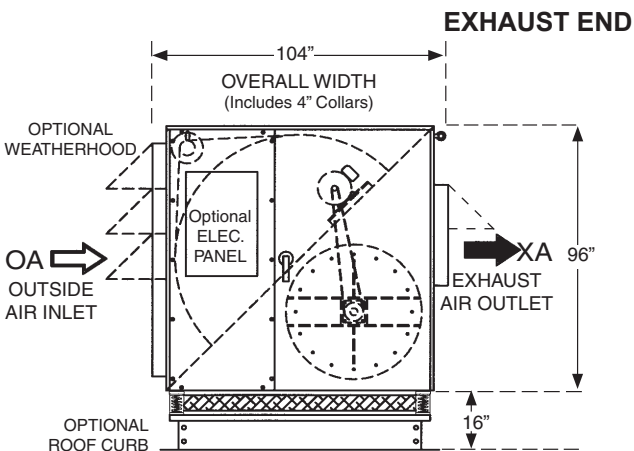

EXHAUST END

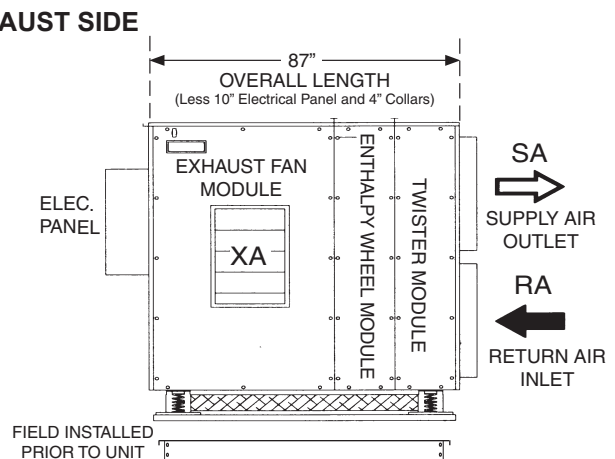

EXHAUST SIDE

SUPPLY FAN PERFORMANCE AND MOTOR SELECTION GUIDE

(Intersect CFM with external static pressure to determine fan h.p.)

CFM	OUTLET VEL. FPM		0.5 ESP	1.0 ESP	1.5 ESP	2.0 ESP	2.5 ESP	3.0 ESP	3.5 ESP
14000	2236	RPM	818	868	915	961	1005	1048	1089
		BHP	5.91	7.07	8.24	9.46	10.69	11.96	13.25
		hp	7.5	10	10	15	15	15	20
14500	2316	RPM	845	893	939	984	1027	1068	1109
		BHP	6.51	7.7	8.91	10.18	11.45	12.72	14.07
		hp	7.5	10	15	15	15	15	20
15000	2396	RPM	896	916	961	1004	1046	1087	1126
		BHP	7.07	8.31	9.57	10.84	12.15	13.49	14.82
		hp	10	10	15	15	15	20	20
15500	2476	RPM	890	935	979	1022	1063	1103	1142
		BHP	7.59	8.84	10.13	11.46	12.8	14.17	15.56
		hp	10	15	15	15	15	20	20
16000	2556	RPM	912	956	999	1041	1081	1120	N/A
		BHP	8.16	9.45	10.78	12.14	13.51	14.9	
		hp	10	15	15	15	20	20	

EXHAUST FAN PERFORMANCE AND MOTOR SELECTION GUIDE

(Intersect CFM with external static pressure to determine fan h.p.)

CFM	OUTLET VEL. FPM		0.5 ESP	1.0 ESP	1.5 ESP	2.0 ESP	2.5 ESP	3.0 ESP	3.5 ESP
14000	2236	RPM	834	883	930	975	1019	1061	1102
		BHP	6.27	7.44	8.63	9.84	11.09	12.36	13.67
		hp	7.5	10	10	15	15	15	20
14500	2316	RPM	862	909	955	998	1041	1082	1122
		BHP	6.92	8.12	9.36	10.58	11.88	13.17	14.51
		hp	10	10	15	15	15	20	20
15000	2396	RPM	887	933	977	1020	1062	1102	1141
		BHP	7.54	8.78	10.03	11.33	12.66	13.99	15.35
		hp	10	15	15	15	15	20	20
15500	2476	RPM	908	953	996	1038	1079	1118	N/A
		BHP	8.08	9.36	10.65	11.98	13.34	14.69	
		hp	10	15	15	15	20	20	
16000	2556	RPM	931	975	1018	1059	1098	1137	N/A
		BHP	8.71	10.03	11.38	12.75	14.1	15.52	
		hp	10	15	15	15	20	20	

FAN MOTOR AMP DRAW CHART

hp	208	240	480
7-1/2	21.0	19.0	9.5
10	27.3	24.7	12.3
15	41.0	38.0	19.0
20	54.0	50.0	24.9

WHEEL MOTOR AMP DRAW CHART

	208	240	480
1/2 hp	1.8	1.8	0.9

ACCESSORIES AMP DRAW CHART

	208	240	480
Enthalpy Wheel Rotation Detection	0.20	0.20	0.10
Damper Motor (ea.)	0.75	0.75	0.50
Radiant Defrost Heater Pkg. (ea.)	4.57	3.95	1.97
Temperature Sensor (ea.)	0.50	0.50	0.25
Lights and Receptical	12.00	12.00	6.00
Variable Frequency Drive for Fan (ea.)	0.50	0.50	0.25

Performance numbers are based on optimum conditions. Consult factory for precise performance.