

SUPPLY END

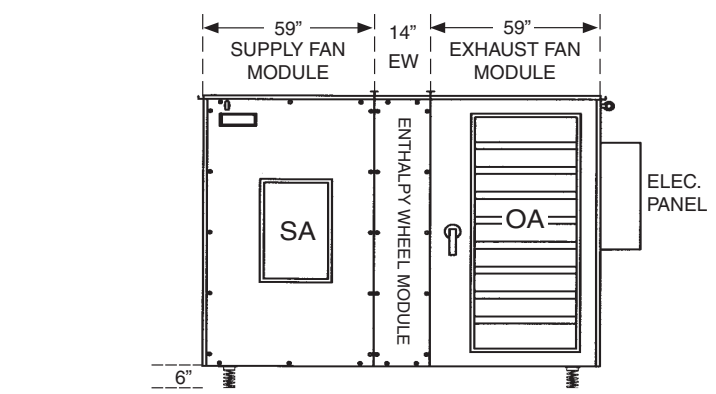

SUPPLY SIDE

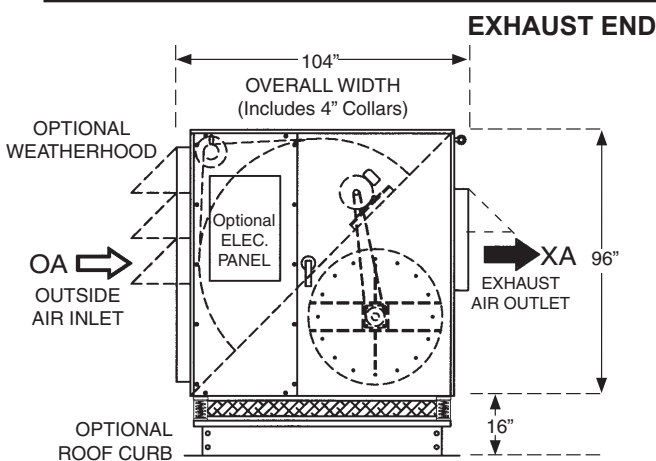

EXHAUST END

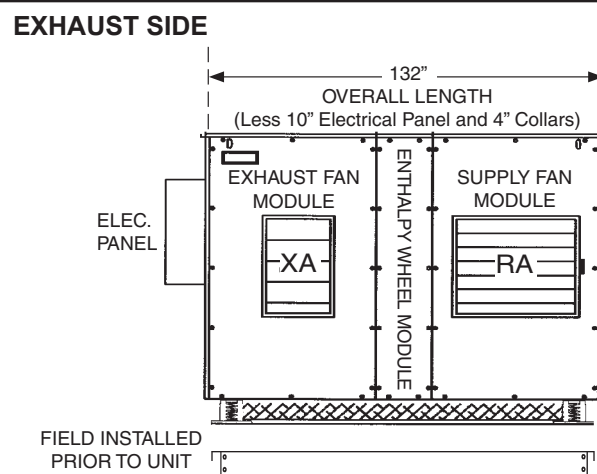

EXHAUST SIDE

8815-ERV

14,000 to 16,000 CFM

December, 2009

SUPPLY FAN PERFORMANCE AND MOTOR SELECTION GUIDE

(Intersect CFM with external static pressure to determine fan h.p.)

| CFM | OUTLET VEL. FPM | | 0.5 ESP | 1.0 ESP | 1.5 ESP | 2.0 ESP | 2.5 ESP | 3.0 ESP | 3.5 ESP |
|-------|-----------------|-----|---------|---------|---------|---------|---------|---------|---------|
| 14000 | 2236 | RPM | 867 | 914 | 960 | 1004 | 1047 | 1088 | 1129 |
| | | BHP | 7.05 | 8.21 | 9.43 | 10.66 | 11.93 | 13.21 | 14.58 |
| | | hp | 10 | 10 | 15 | 15 | 15 | 20 | 20 |
| 14500 | 2316 | RPM | 893 | 939 | 984 | 1027 | 1068 | 1109 | N/A |
| | | BHP | 7.7 | 8.91 | 10.18 | 11.45 | 12.72 | 14.07 | |
| | | hp | 10 | 15 | 15 | 15 | 15 | 20 | |
| 15000 | 2396 | RPM | 917 | 962 | 1006 | 1048 | 1088 | 1128 | N/A |
| | | BHP | 8.34 | 9.6 | 10.9 | 12.21 | 13.52 | 14.89 | |
| | | hp | 10 | 15 | 15 | 15 | 20 | 20 | |
| 15500 | 2476 | RPM | 940 | 984 | 1026 | 1067 | 1107 | N/A | N/A |
| | | BHP | 8.98 | 10.28 | 11.59 | 12.94 | 14.31 | | |
| | | hp | 15 | 15 | 15 | 15 | 20 | | |
| 16000 | 2556 | RPM | 962 | 1005 | 1046 | N/A | 1126 | N/A | NA |
| | | BHP | 9.63 | 10.97 | 12.31 | | 15.12 | | |
| | | hp | 15 | 15 | 15 | | 20 | | |

EXHAUST FAN PERFORMANCE AND MOTOR SELECTION GUIDE

(Intersect CFM with external static pressure to determine fan h.p.)

| CFM | OUTLET VEL. FPM | | 0.5 ESP | 1.0 ESP | 1.5 ESP | 2.0 ESP | 2.5 ESP | 3.0 ESP | 3.5 ESP |
|-------|-----------------|-----|---------|---------|---------|---------|---------|---------|---------|
| 14000 | 2236 | RPM | 843 | 892 | 938 | 983 | 1026 | 1069 | 1110 |
| | | BHP | 6.48 | 7.66 | 8.84 | 10.06 | 11.3 | 12.61 | 13.94 |
| | | hp | 7.5 | 10 | 15 | 15 | 15 | 20 | 20 |
| 14500 | 2316 | RPM | 870 | 917 | 963 | 1006 | 1048 | 1089 | 1130 |
| | | BHP | 7.12 | 8.33 | 9.58 | 10.82 | 12.09 | 13.4 | 14.79 |
| | | hp | 10 | 10 | 15 | 15 | 15 | 20 | 20 |
| 15000 | 2396 | RPM | 896 | 942 | 986 | 1028 | 1070 | 1110 | N/A |
| | | BHP | 7.78 | 9.03 | 10.3 | 11.58 | 12.92 | 14.26 | |
| | | hp | 10 | 15 | 15 | 15 | 15 | 20 | |
| 15500 | 2476 | RPM | 917 | 962 | 1005 | 1047 | 1087 | 1126 | N/A |
| | | BHP | 8.33 | 9.63 | 10.93 | 12.27 | 13.61 | 14.98 | |
| | | hp | 10 | 15 | 15 | 15 | 20 | 20 | |
| 16000 | 2556 | RPM | 940 | 984 | 1026 | 1067 | 1106 | N/A | NA |
| | | BHP | 8.97 | 10.3 | 11.64 | 13.02 | 14.39 | | |
| | | hp | 15 | 15 | 15 | 15 | 20 | | |

FAN MOTOR AMP DRAW CHART

| hp | 208 | 240 | 480 |
|-------|------|------|------|
| 7-1/2 | 21.0 | 19.0 | 9.5 |
| 10 | 27.3 | 24.7 | 12.3 |
| 15 | 41.0 | 38.0 | 19.0 |
| 20 | 54.0 | 50.0 | 24.9 |

WHEEL MOTOR AMP DRAW CHART

| | 208 | 240 | 480 |
|--------|-----|-----|-----|
| 1/2 hp | 1.8 | 1.8 | 0.9 |

ACCESSORIES AMP DRAW CHART

| | 208 | 240 | 480 |
|--|-------|-------|------|
| Enthalpy Wheel Rotation Detection | 0.20 | 0.20 | 0.10 |
| Damper Motor (ea.) | 0.75 | 0.75 | 0.50 |
| Radiant Defrost Heater Pkg. (ea.) | 4.57 | 3.95 | 1.97 |
| Temperature Sensor (ea.) | 0.50 | 0.50 | 0.25 |
| Lights and Receptical | 12.00 | 12.00 | 6.00 |
| Variable Frequency Drive for Fan (ea.) | 0.50 | 0.50 | 0.25 |

Performance numbers are based on optimum conditions. Consult factory for precise performance.

Berner International Corp.

111 Progress Avenue, New Castle, PA 16101 / Telephone (724) 657-5301 / FAX (724) 652-0682 / www.berner.com / info@bernerenergy.com

©Copyright, 2009 Berner International Corp.