

**SUPPLY END**

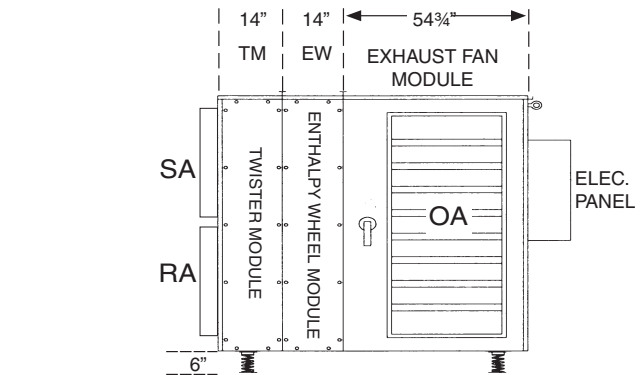

**SUPPLY SIDE**

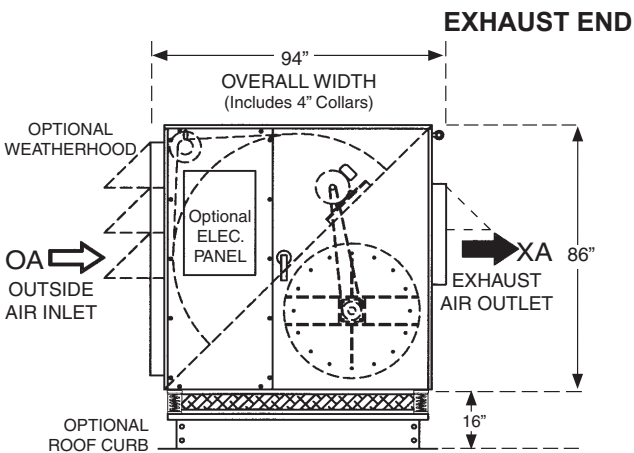

**EXHAUST END**

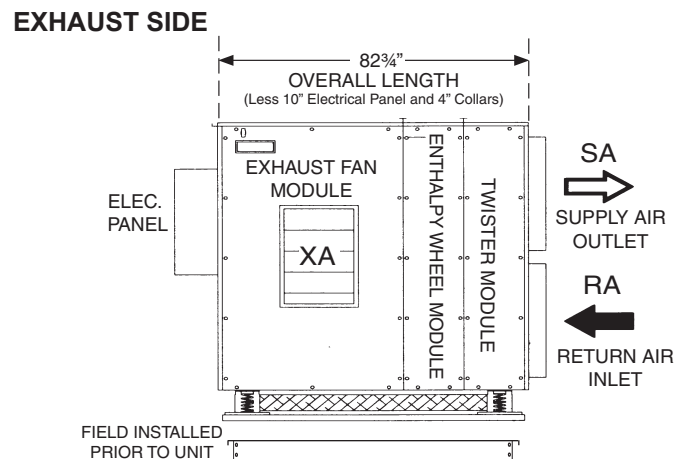

**EXHAUST SIDE**

## SUPPLY FAN PERFORMANCE AND MOTOR SELECTION GUIDE

(Intersect CFM with external static pressure to determine fan h.p.)

CFM	OUTLET VEL. FPM		0.5 ESP	1.0 ESP	1.5 ESP	2.0 ESP	2.5 ESP	3.0 ESP	3.5 ESP
11000	2128	RPM	872	928	982	1034	1084	1132	1179
		BHP	4.45	5.36	6.3	7.26	8.25	9.26	10.31
		hp	7.5	7.5	7.5	10	10	15	15
11500	2224	RPM	903	958	1010	1060	1108	1155	1201
		BHP	4.94	5.9	6.87	7.86	8.87	9.91	11
		hp	7.5	7.5	10	10	15	15	15
12000	2321	RPM	937	989	1040	1089	1135	1181	1226
		BHP	5.52	6.49	7.52	8.56	9.95	10.67	11.79
		hp	7.5	7.5	10	10	15	15	15
12500	2418	RPM	966	1017	1066	1113	1159	1204	1247
		BHP	6.04	7.07	8.11	9.17	10.26	11.38	12.51
		hp	7.5	10	10	15	15	15	15
13000	2515	RPM	993	1043	1091	1137	1182	1225	N/A
		BHP	6.55	7.62	8.71	9.81	10.94	12.07	
		hp	10	10	15	15	15	15	

## EXHAUST FAN PERFORMANCE AND MOTOR SELECTION GUIDE

(Intersect CFM with external static pressure to determine fan h.p.)

CFM	OUTLET VEL. FPM		0.5 ESP	1.0 ESP	1.5 ESP	2.0 ESP	2.5 ESP	3.0 ESP	3.5 ESP
11000	2128	RPM	891	947	1000	1051	1100	1148	1195
		BHP	4.75	5.68	6.62	7.59	8.58	9.61	10.29
		hp	7.5	7.5	10	10	10	15	15
11500	2224	RPM	924	978	1029	1079	1126	1173	1218
		BHP	5.3	6.26	7.24	8.26	9.26	10.33	11.42
		hp	7.5	7.5	10	10	15	15	15
12000	2321	RPM	959	1011	1060	1108	1155	1200	1244
		BHP	5.92	6.93	7.93	8.98	10.05	11.14	12.26
		hp	7.5	10	10	15	15	15	15
12500	2418	RPM	990	1040	1088	1135	1180	1224	N/A
		BHP	6.51	7.55	8.6	9.96	10.78	11.9	
		hp	7.5	10	10	15	15	15	
13000	2515	RPM	1018	1067	1114	1159	1203	1246	1102
		BHP	7.08	8.16	9.25	10.35	11.48	12.63	13.32
		hp	10	10	15	15	15	15	20

### FAN MOTOR AMP DRAW CHART

hp	208	240	480
7-1/2	21.0	19.0	9.5
10	27.3	24.7	12.3
15	41.0	38.0	19.0
20	54.0	50.0	24.9

### WHEEL MOTOR AMP DRAW CHART

	208	240	480
1/3 hp	1.2	1.2	0.6

### ACCESSORIES AMP DRAW CHART

	208	240	480
Enthalpy Wheel Rotation Detection	0.20	0.20	0.10
Damper Motor (ea.)	0.75	0.75	0.50
Radiant Defrost Heater Pkg. (ea.)	4.57	3.95	1.97
Temperature Sensor (ea.)	0.50	0.50	0.25
Lights and Receptical	12.00	12.00	6.00
Variable Frequency Drive for Fan (ea.)	0.50	0.50	0.25

Performance numbers are based on optimum conditions. Consult factory for precise performance.