

SUPPLY END

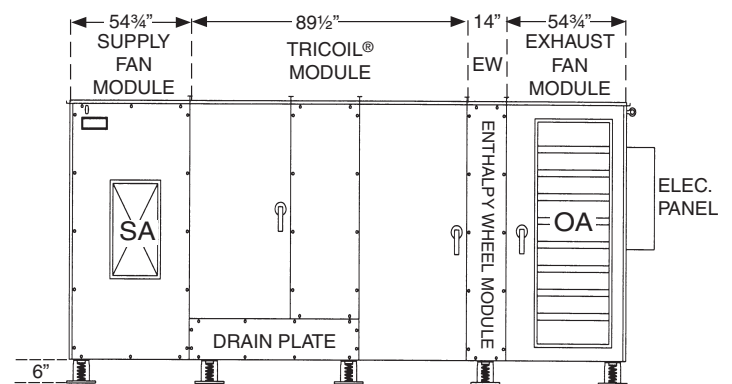

SUPPLY SIDE

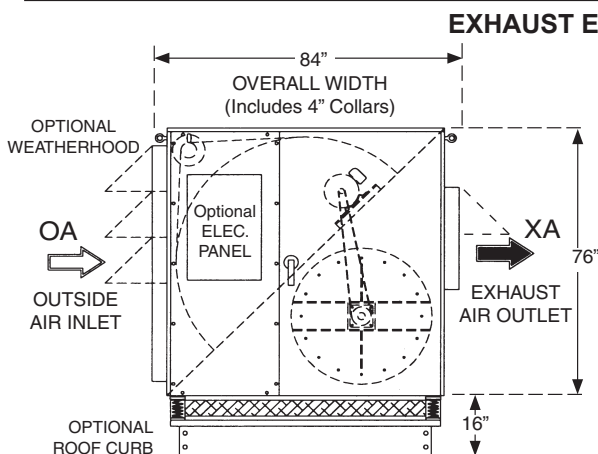

EXHAUST END

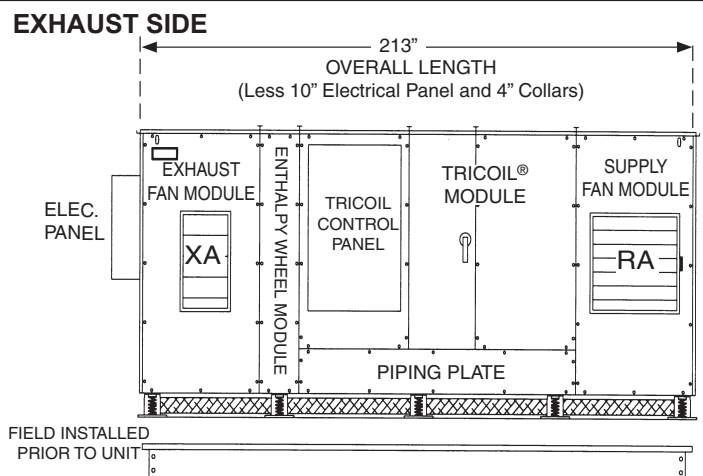

EXHAUST SIDE

SUPPLY FAN PERFORMANCE AND MOTOR SELECTION GUIDE

(Intersect CFM with external static pressure to determine fan h.p.)

CFM	OUTLET VEL. FPM		0.5 ESP	1.0 ESP	1.5 ESP	2.0 ESP	2.5 ESP	3.0 ESP	3.5 ESP
9000	2148	RPM BHP hp	1253 7.45 10	1305 8.3 10	1355 9.17 15	N/A	N/A	N/A	N/A
9250	2208	RPM BHP hp	1290 8.12 10	1347 9.01 15	1390 9.9 15	N/A	N/A	N/A	N/A
9500	2267	RPM BHP hp	1326 8.82 15	1376 9.73 15	N/A	N/A	N/A	N/A	N/A
9750	2327	RPM BHP hp	1352 9.37 15	N/A	N/A	N/A	N/A	N/A	N/A
10000	2387	RPM BHP hp	1382 10.02 15	N/A	N/A	N/A	N/A	N/A	N/A

EXHAUST FAN PERFORMANCE AND MOTOR SELECTION GUIDE

(Intersect CFM with external static pressure to determine fan h.p.)

CFM	OUTLET VEL. FPM		0.5 ESP	1.0 ESP	1.5 ESP	2.0 ESP	2.5 ESP	3.0 ESP	3.5 ESP
9000	2148	RPM BHP hp	1031 4.34 5	1091 5.11 7.5	1148 5.89 7.5	1203 6.68 10	1257 7.51 10	1309 8.37 10	1359 9.24 15
9250	2208	RPM BHP hp	1050 4.59 7.5	1109 5.37 7.5	1165 6.17 7.5	1220 7 10	1272 7.82 10	1324 8.71 15	1373 9.59 15
9500	2267	RPM BHP hp	1071 4.87 7.5	1129 5.68 7.5	1184 6.49 7.5	1237 7.32 10	1289 8.18 10	1339 9.05 15	1389 9.98 15
9750	2327	RPM BHP hp	1091 5.15 7.5	1147 5.96 7.5	1202 6.81 10	1254 7.65 10	1305 8.52 10	1354 9.41 15	N/A
10000	2387	RPM BHP hp	1110 5.42 7.5	1165 6.25 7.5	1218 7.1 10	1270 7.98 10	1320 8.86 15	1369 9.77 15	N/A

hp	208	240	480
5	14.0	12.7	6.4
7.5	21.0	19.0	9.5
10	27.3	24.7	12.3
15	41.0	38.0	19.0

	208	240	480
1/3 hp	1.2	1.2	0.6

Performance numbers are based on optimum conditions. Consult factory for precise performance.

	208	240	480
Enthalpy Wheel Rotation Detection	0.20	0.20	0.10
Damper Motor (ea.)	0.75	0.75	0.50
Radiant Defrost Heater Pkg. (ea.)	4.57	3.95	1.97
TRICOIL Pump Motor	4.00	4.00	2.00
Hot Water Modulating Ball-Valve	0.20	0.20	0.10
Temperature Sensor (ea.)	0.50	0.50	0.25
Lights and Receptical	12.00	12.00	6.00
Variable Frequency Drive for Fan (ea.)	0.50	0.50	0.25
Variable Frequency Drive for TRICOIL	0.25	0.25	0.15