

SUPPLY END

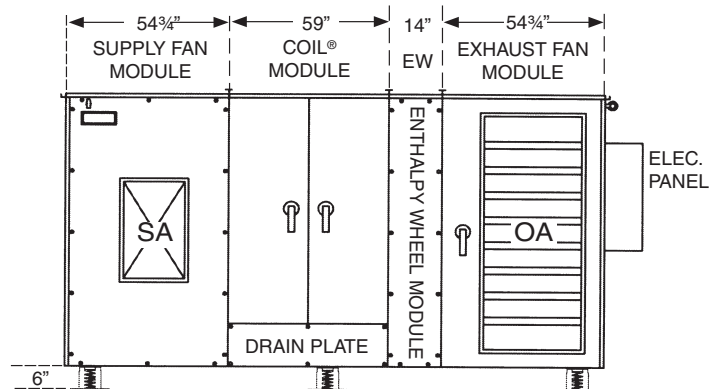

SUPPLY SIDE

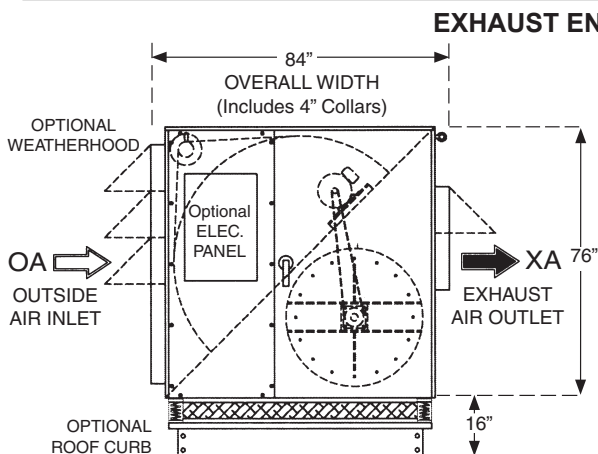

EXHAUST END

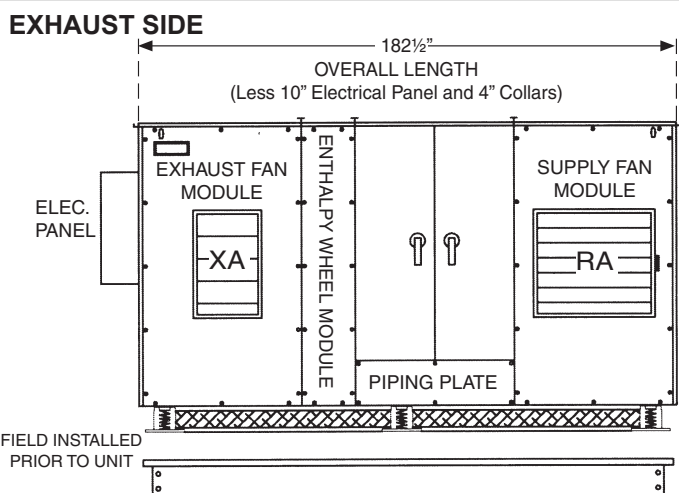

EXHAUST SIDE

SUPPLY FAN PERFORMANCE AND MOTOR SELECTION GUIDE

(Intersect CFM with external static pressure to determine fan h.p.)

CFM	OUTLET VEL. FPM		0.5 ESP	1.0 ESP	1.5 ESP	2.0 ESP	2.5 ESP	3.0 ESP	3.5 ESP
9000	2148	RPM	1157	1212	1265	1317	1367	N/A	N/A
		BHP	6.01	6.82	7.64	8.5	9.38		
		hp	7.5	10	10	10	15		
9250	2208	RPM	1181	1234	1287	1338	1387	N/A	N/A
		BHP	6.41	7.21	8.07	8.95	9.85		
		hp	7.5	10	10	15	15		
9500	2267	RPM	1202	1255	1306	1356	N/A	N/A	N/A
		BHP	6.77	7.61	8.47	9.36			
		hp	10	10	10	15			
9750	2327	RPM	1226	1278	1328	1377	N/A	N/A	N/A
		BHP	7.19	8.06	8.93	9.84			
		hp	10	10	15	15			
10000	2387	RPM	1257	1307	1356	N/A	N/A	N/A	N/A
		BHP	7.75	8.63	9.52				
		hp	10	10	15				

EXHAUST FAN PERFORMANCE AND MOTOR SELECTION GUIDE

(Intersect CFM with external static pressure to determine fan h.p.)

CFM	OUTLET VEL. FPM		0.5 ESP	1.0 ESP	1.5 ESP	2.0 ESP	2.5 ESP	3.0 ESP	3.5 ESP
9000	2148	RPM	1031	1091	1148	1203	1257	1309	1359
		BHP	4.34	5.11	5.89	6.68	7.51	8.37	9.24
		hp	5	7.5	7.5	10	10	10	15
9250	2208	RPM	1050	1109	1165	1220	1272	1324	1373
		BHP	4.59	5.37	6.17	7	7.82	8.71	9.59
		hp	7.5	7.5	7.5	10	10	15	15
9500	2267	RPM	1071	1129	1184	1237	1289	1339	1389
		BHP	4.87	5.68	6.49	7.32	8.18	9.05	9.98
		hp	7.5	7.5	7.5	10	10	15	15
9750	2327	RPM	1091	1147	1202	1254	1305	1354	N/A
		BHP	5.15	5.96	6.81	7.65	8.52	9.41	
		hp	7.5	7.5	10	10	10	15	
10000	2387	RPM	1110	1165	1218	1270	1320	1369	N/A
		BHP	5.42	6.25	7.1	7.98	8.86	9.77	
		hp	7.5	7.5	10	10	15	15	

hp	208	240	480
5	14.0	12.7	6.4
7.5	21.0	19.0	9.5
10	27.3	24.7	12.3
15	41.0	38.0	19.0

	208	240	480
1/3 hp	1.2	1.2	0.6

	208	240	480
Enthalpy Wheel Rotation Detection	0.20	0.20	0.10
Damper Motor (ea.)	0.75	0.75	0.50
Radiant Defrost Heater Pkg. (ea.)	4.57	3.95	1.97
Temperature Sensor (ea.)	0.50	0.50	0.25
Lights and Receptical	12.00	12.00	6.00
Variable Frequency Drive for Fan (ea.)	0.50	0.50	0.25

Performance numbers are based on optimum conditions. Consult factory for precise performance.