

**SUPPLY END**

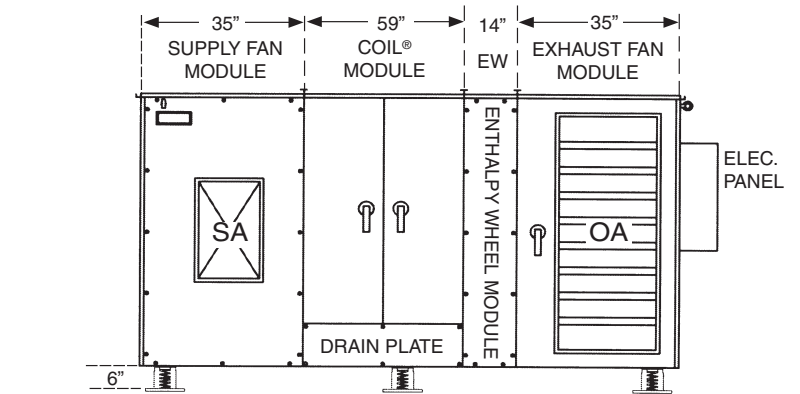

**SUPPLY SIDE**

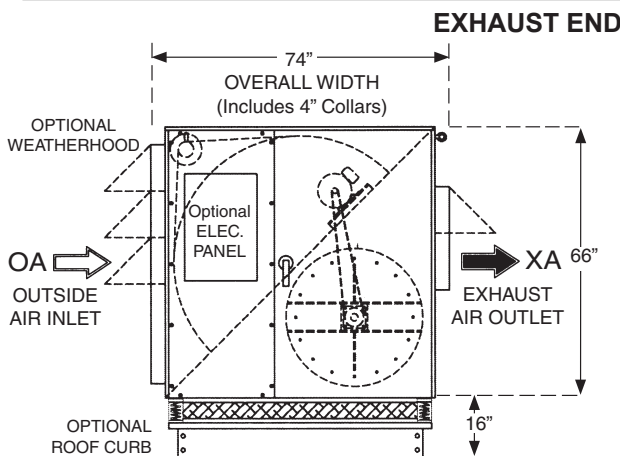

**EXHAUST END**

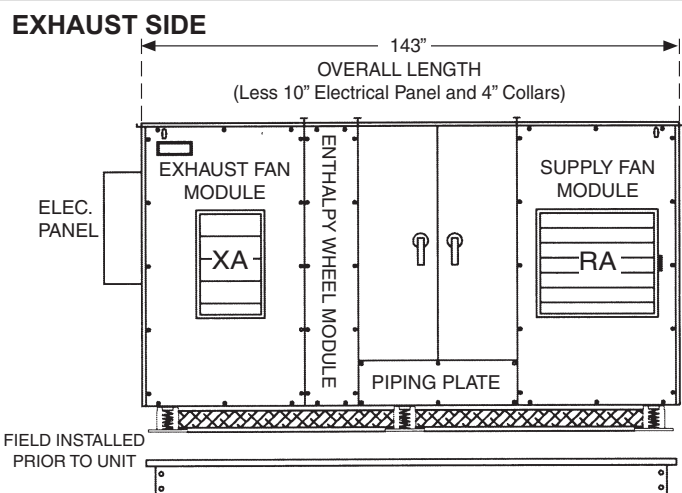

**EXHAUST SIDE**

## SUPPLY FAN PERFORMANCE AND MOTOR SELECTION GUIDE

(Intersect CFM with external static pressure to determine fan h.p.)

CFM	OUTLET VEL. FPM		0.5 ESP	1.0 ESP	1.5 ESP	2.0 ESP	2.5 ESP	3.0 ESP	3.5 ESP
3500	1824	RPM	1440	1654	1654	1756	1854	1949	2042
		BHP	1.6	2.28	2.28	2.65	3.04	3.43	3.85
		hp	2	3	3	5	5	5	5
3750	1954	RPM	1517	1719	1719	1816	1910	2001	2089
		BHP	1.88	2.6	2.6	2.99	3.39	3.8	4.23
		hp	3	3	3	5	5	5	5
4000	2084	RPM	1587	1684	1779	1871	1961	2048	N/A
		BHP	2.17	2.54	2.92	3.32	3.74	4.16	
		hp	3	3	5	5	5	5	
4250	2215	RPM	1661	1753	1843	1931	2017	2101	N/A
		BHP	2.49	2.88	3.28	3.7	4.13	4.58	
		hp	3	5	5	5	5	7.5	
4500	2345	RPM	1750	1838	1923	2007	2089	N/A	N/A
		BHP	2.92	3.33	3.75	4.19	4.64		
		hp	5	5	5	5	7.5		

## EXHAUST FAN PERFORMANCE AND MOTOR SELECTION GUIDE

(Intersect CFM with external static pressure to determine fan h.p.)

CFM	OUTLET VEL. FPM		0.5 ESP	1.0 ESP	1.5 ESP	2.0 ESP	2.5 ESP	3.0 ESP	3.5 ESP
3500	1824	RPM	1309	1422	1532	1638	1740	1839	1934
		BHP	1.24	1.55	1.88	2.23	2.59	2.98	3.37
		hp	1.5	2	3	3	3	5	5
3750	1954	RPM	1370	1477	1581	1682	1779	1874	1966
		BHP	1.42	1.75	2.1	2.46	2.84	3.23	3.64
		hp	2	3	3	3	5	5	5
4000	2084	RPM	1432	1533	1632	1728	1822	1913	2001
		BHP	1.63	1.97	2.33	2.71	3.1	3.51	3.93
		hp	2	3	3	5	5	5	5
4250	2215	RPM	1499	1595	1689	1781	1870	1957	2042
		BHP	1.87	2.23	2.61	3.01	3.41	3.83	4.26
		hp	3	3	5	5	5	5	5
4500	2345	RPM	1568	1659	1749	1836	1922	2006	2087
		BHP	2.14	2.52	2.92	3.32	3.75	4.18	4.63
		hp	3	3	5	5	5	5	7.5

### FAN MOTOR AMP DRAW CHART

hp	208	240	480
1-1/2	4.5	4.4	2.2
2	6.0	5.9	3.0
3	8.6	8.4	4.2
5	14.0	12.7	6.4
7.5	21.0	19.0	9.5

### WHEEL MOTOR AMP DRAW CHART

	208	240	480
1/4 hp	1.0	1.0	0.5

### ACCESSORIES AMP DRAW CHART

	208	240	480
Enthalpy Wheel Rotation Detection	0.20	0.20	0.10
Damper Motor (ea.)	0.75	0.75	0.50
Radiant Defrost Heater Pkg. (ea.)	4.57	3.95	1.97
Temperature Sensor (ea.)	0.50	0.50	0.25
Lights and Receptical	12.00	12.00	6.00
Variable Frequency Drive for Fan (ea.)	0.50	0.50	0.25

Performance numbers are based on optimum conditions. Consult factory for precise performance.