

**SUPPLY END**

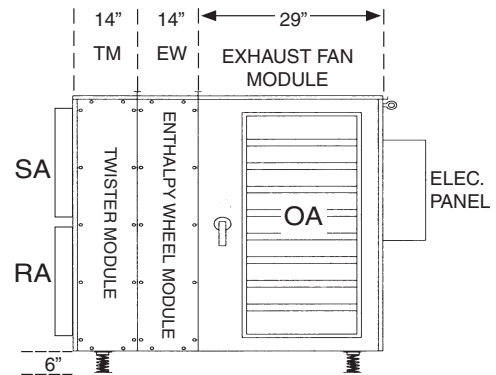

**SUPPLY SIDE**

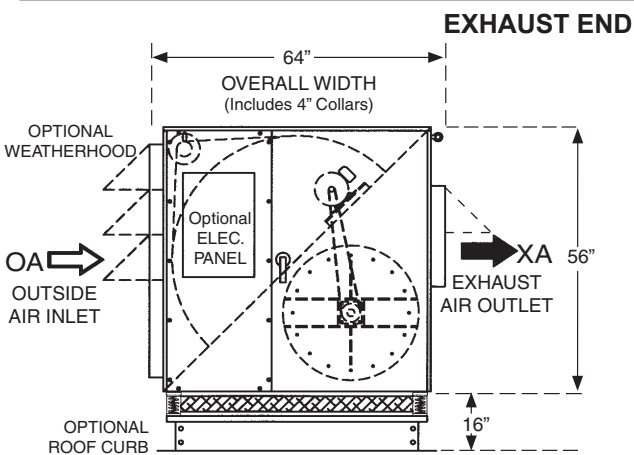

**EXHAUST END**

**EXHAUST SIDE**

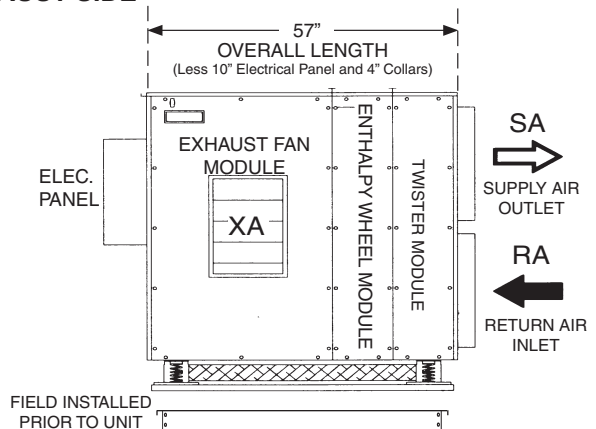

## SUPPLY FAN PERFORMANCE AND MOTOR SELECTION GUIDE

(Intersect CFM with external static pressure to determine fan h.p.)

CFM	OUTLET VEL. FPM		0.5 ESP	1.0 ESP	1.5 ESP	2.0 ESP	2.5 ESP	3.0 ESP	3.5 ESP
2500	1592	RPM	1320	1453	1575	1689	1796	1901	2003
		BHP	0.78	1.02	1.28	1.56	1.85	2.15	2.48
		hp	1	1.5	1.5	2	3	3	3
2750	1752	RPM	1397	1524	1640	1749	1852	1951	2047
		BHP	0.92	1.19	1.46	1.75	2.06	2.37	2.71
		hp	1.5	1.5	2	3	3	3	5
3000	1911	RPM	1486	1606	1717	1821	1920	2015	2105
		BHP	1.11	1.4	1.69	2	2.31	2.65	2.99
		hp	1.5	2	2	3	3	5	5
3250	2070	RPM	1583	1697	1803	1902	1996	2087	2174
		BHP	1.34	1.65	1.97	2.29	2.62	2.97	3.33
		hp	2	2	3	3	5	5	5
3500	2229	RPM	1663	1773	1875	1971	2062	2149	2234
		BHP	1.55	1.88	2.22	2.56	2.91	3.27	3.65
		hp	2	3	3	3	5	5	5

## EXHAUST FAN PERFORMANCE AND MOTOR SELECTION GUIDE

(Intersect CFM with external static pressure to determine fan h.p.)

CFM	OUTLET VEL. FPM		0.5 ESP	1.0 ESP	1.5 ESP	2.0 ESP	2.5 ESP	3.0 ESP	3.5 ESP
2500	1592	RPM	1351	1481	1601	1713	1820	1924	2026
		BHP	0.83	1.08	1.34	1.62	1.91	2.22	2.55
		hp	1	1.5	2	2	3	3	3
2750	1752	RPM	1431	1555	1669	1777	1878	1976	2071
		BHP	0.99	1.26	1.54	1.83	2.14	2.46	2.79
		hp	1.5	1.5	2	3	3	3	5
3000	1911	RPM	1526	1643	1751	1853	1951	2044	2134
		BHP	1.2	1.49	1.79	2.1	2.42	2.76	3.11
		hp	1.5	2	3	3	3	5	5
3250	2070	RPM	1627	1738	1841	1938	2031	2121	2206
		BHP	1.45	1.77	2.09	2.41	2.75	3.11	3.47
		hp	2	3	3	3	5	5	5
3500	2229	RPM	1715	1821	1920	2013	2102	2189	2272
		BHP	1.7	2.04	2.38	2.72	3.08	3.45	3.82
		hp	2	3	3	5	5	5	5

### FAN MOTOR AMP DRAW CHART

hp	208	240	480
1	3.1	3.0	1.5
1-1/2	4.5	4.4	2.2
2	6.0	5.9	3.0
3	8.6	8.4	4.2
5	14.0	12.7	6.4

### WHEEL MOTOR AMP DRAW CHART

	208	240	480
1/4 hp	1.0	1.0	0.5

### ACCESSORIES AMP DRAW CHART

	208	240	480
Enthalpy Wheel Rotation Detection	0.20	0.20	0.10
Damper Motor (ea.)	0.75	0.75	0.50
Radiant Defrost Heater Pkg. (ea.)	4.57	3.95	1.97
Temperature Sensor (ea.)	0.50	0.50	0.25
Lights and Receptical	12.00	12.00	6.00
Variable Frequency Drive for Fan (ea.)	0.50	0.50	0.25

Performance numbers are based on optimum conditions. Consult factory for precise performance.