

SUPPLY END

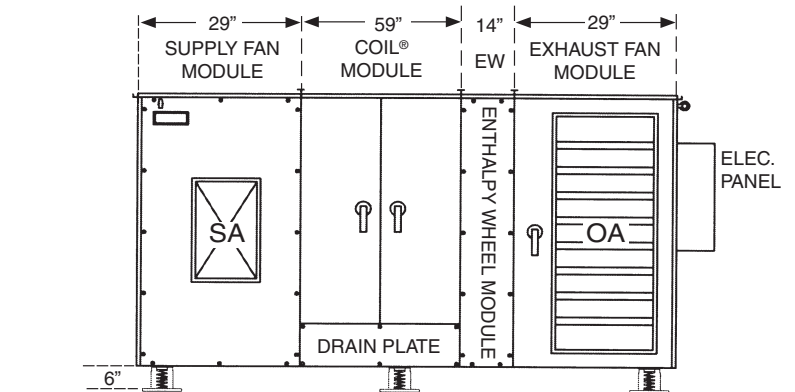

SUPPLY SIDE

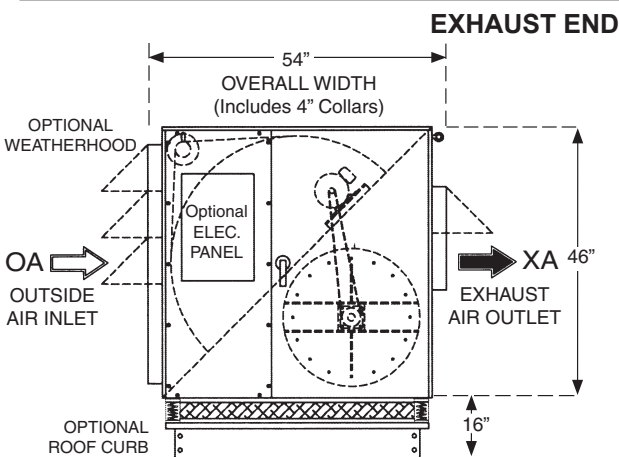

EXHAUST END

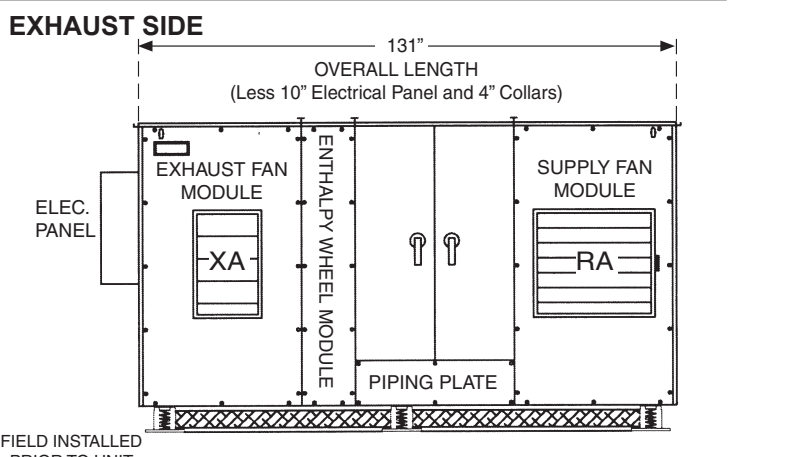

EXHAUST SIDE

SUPPLY FAN PERFORMANCE AND MOTOR SELECTION GUIDE

(Intersect CFM with external static pressure to determine fan h.p.)

CFM	OUTLET VEL. FPM		0.5 ESP	1.0 ESP	1.5 ESP	2.0 ESP	2.5 ESP	3.0 ESP	3.5 ESP
1500	1430	RPM	1774	1924	2068	2207	N/A	N/A	N/A
		BHP	0.67	0.84	1.02	1.21			
		hp	1	1	1.5	1.5			
1750	1668	RPM	1938	2076	2206	2331	2453	2572	2687
		BHP	0.88	1.07	1.27	1.47	1.69	1.92	2.15
		hp	1.5	1.5	1.5	2	2	3	3
2000	1907	RPM	2137	2262	2381	2495	2605	2713	2819
		BHP	1.19	1.4	1.61	1.84	2.07	2.31	2.56
		hp	1.5	2	2	3	3	3	3
2250	2145	RPM	2332	2446	2556	2663	2765	2864	N/A
		BHP	1.56	1.78	2.01	2.26	2.51	2.77	
		hp	2	3	3	3	3	5	
2500	2383	RPM	2522	2628	2730	2830	N/A	N/A	N/A
		BHP	1.98	2.22	2.47	2.74			
		hp	3	3	3	5			

EXHAUST FAN PERFORMANCE AND MOTOR SELECTION GUIDE

(Intersect CFM with external static pressure to determine fan h.p.)

CFM	OUTLET VEL. FPM		0.5 ESP	1.0 ESP	1.5 ESP	2.0 ESP	2.5 ESP	3.0 ESP	3.5 ESP
1500	1430	RPM	1597	1761	1913	2057	2196	N/A	N/A
		BHP	0.5	0.65	0.82	1	1.2		
		hp	1	1	1	1.5	2		
1750	1668	RPM	1757	1907	2047	2178	2303	2426	2546
		BHP	0.67	0.84	1.03	1.22	1.43	1.64	1.87
		hp	1	1	1.5	1.5	2	2	3
2000	1907	RPM	1928	2066	2195	2317	2434	2546	2655
		BHP	0.98	1.08	1.28	1.49	1.71	1.94	2.18
		hp	1.5	1.5	1.5	2	2	3	3
2250	2145	RPM	2092	2220	2341	2455	2565	2671	2773
		BHP	1.13	1.35	1.57	1.8	2.03	2.28	2.53
		hp	1.5	2	2	3	3	3	3
2500	2383	RPM	2269	2388	2502	2609	2712	2812	N/A
		BHP	1.45	1.69	1.93	2.18	2.43	2.69	
		hp	2	2	3	3	3	5	

FAN MOTOR AMP DRAW CHART

hp	208	240	480
1	3.1	3.0	1.5
1-1/2	4.5	4.4	2.2
2	6.0	5.9	3.0
3	8.6	8.4	4.2
5	14.0	12.7	6.4

WHEEL MOTOR AMP DRAW CHART

	208	240	480
1/4 hp	1.0	1.0	0.5

ACCESSORIES AMP DRAW CHART

	208	240	480
Enthalpy Wheel Rotation Detection	0.20	0.20	0.10
Damper Motor (ea.)	0.75	0.75	0.50
Radiant Defrost Heater Pkg. (ea.)	4.57	3.95	1.97
Temperature Sensor (ea.)	0.50	0.50	0.25
Lights and Receptical	12.00	12.00	6.00
Variable Frequency Drive for Fan (ea.)	0.50	0.50	0.25

Performance numbers are based on optimum conditions. Consult factory for precise performance.